



MT. SAC BUILDING 2 CHILLER AND COOLING TOWER EVALUATION



May 20, 2010

Prepared by:
p2s

P2S Engineering, Inc.
5000 East Spring Street,
Eighth Floor
Long Beach, CA 90815

1.0 EXECUTIVE SUMMARY

1.1 Background and Scope

P2S Engineering was retained by MT. SAC (Mt. San Antonio Community College) to conduct an evaluation of the existing chiller and cooling tower installation located in Building 2 of Walnut, CA; and identify options for the refurbishment or replacement of the equipment.

The objective of this evaluation is to :

- Identify existing installation and evaluate the condition of the associated chilled water and cooling tower equipment.
- Determine existing system configuration and feasibility of implementation of the TES system
- Evaluate the energy consumption of the existing configuration
- Determine if connection to existing campus central plant is an option.

The scope of this study involves:

- Evaluating existing mechanical systems and their related control configurations,
- Evaluating existing hydronic systems, analysis of piping distribution and control configurations,

1.2 Methodology

Following methodology was adopted in identifying potential energy savings measures:

1. Reviewing existing drawings and performing field investigation. The following information was gathered from the existing drawings and field investigation:
 - a. Configurations of installed equipment.
 - b. Equipment operation, level of control and strategies.
 - c. Nameplate data for HVAC components, chillers, cooling towers and associated pumps.
 - d. System control schematic diagrams.
 - e. Apparent system deficiencies.
2. Identifying opportunities and options for system modifications and

This task included:

- a. Identifying Replacement equipment with higher efficiency Equipment
5. Performing economic savings analysis and calculating Rough Order Magnitude costs
6. Presenting recommendations for implementation.

2 Summary of Existing Conditions

An estimate of installed equipment capacities for heating, cooling, lighting and domestic hot water loads is summarized below for the ten buildings being analyzed for energy conservation.

Table 1 Summary of Installed capacities

Bldg	Conditioned Area, ft ²	Cooling	Tons				
2	40502	Chiller 1	150				
2	40502	Chiller 2	280				
Totals	40502		430				

The following attachments were used in preparing the table above

Exhibit-A1 Building 02 Equipment Schedules

Detailed discussions of installed capacities, observations on energy utilization, methods and/or calculation to derive capacities are discussed on individual building’s existing condition commentary. The building does not have sub-metering chilled water supply, chiller or cooling tower energy consumption.

There is no sub-metering on the individual buildings to help study energy consumption by end use. For the purpose of this project, we provided data loggers to monitor the electricity consumption (Amps) of the cooling tower and chiller equipment.

See exhibit A for existing equipment schedules.

See Exhibit B for equipment documentation from factory.

See Exhibit C for Proposed Replacement Equipment Selections.

See Exhibit D for Plant Piping Schematics

2.1 Building # 2 Observations & Findings

1. Building-2 is a two story building performing arts building consisting of classrooms, studios, and auditoriums.
2. **Cooling:** Building-2 is cooled by its own water cooled chiller plant supplying chilled water to various Air Handling Units and fan coils.
3. The existing cooling towers are operating beyond their useful life cycle. The physical structure of the equipment shows a great amount of corrosion. The fill media and associated piping show excessive deterioration and probably operate at a diminished capacity thus resulting in low efficiencies.
4. Chiller-1 has been designed to charge the TES system at non-peak hours, however is currently used to supplement the cooling when CH-2 is not able to meet load.
5. Chiller-2 is a 200 ton centrifugal chiller and is used as the main chiller for meeting the cooling capacities of the building. In discussion with the Facilities Department, this chiller has been through extensive maintenance to maintain operation.
6. The building employs the use of a Thermal Energy Storage System in the form of ice, however the system does not seem to be in operation; this is corroborated by the electrical usage monitoring devices.
7. The chillers serve (4) Air Handlers and various chilled water fan coils throughout the building.
8. Operating hours for the building are from 7:00am to 10:00pm in the evening, with some performances extending into the later hours of the evening.
9. See Exhibits D-1 through D-9 for schematics of the existing condenser water and chilled water system.



EXISTING BUILDING 2 COOLING TOWER



FILL MEDIA CONDITION – EXTENSIVE DAMAGE



COOLING TOWER BASE – EXTENSIVE CORROSIVE DAMAGE



CHILLER - 2



CHILLER - 2 - SIGNS OF LEAKAGE



CHILLED WATER CONNECTION FROM CAMPUS CENTRAL PLANT



EXISTING PNEUMATIC CONTROLS



EXISTING CHILLED WATER PUMPS

3.0 Building Evaluation

The plant currently functions to deliver necessary capacities to the building. However, capacities and capabilities of the central plant bear review if the plant is to feed chilled water services to the building and as the campus continues to grow.

The connected cooling load will eventually exceed the deliverable capacity of the chiller plant. Even before then, the plant will demonstrate deficiencies which bear consideration for modification and upgrade. Deficiencies are as follows:

- Under condition of low CHW return temperature, the chiller plant is unable to develop design tonnage.
- The deliverable flowrate to the building is limited by the available primary CHW flowrate and pumping capacity.
- Deliverable cooling capacity from the central chiller plant is a maximum of 300 tons. This capacity de-rates on occasions when the chillers deliver CHW supply temperature below original design conditions. This capacity also assumes that the campus CHW temperature differential is adequate and does not impose on the deliverable capacity of the chillers.

On the accounts cited here, there is opportunity to improve the performance of the building's chiller plant services by improvement of the performance of connected loads.

Existing Building Controls:

The original control system is based on a pneumatic system. There are basic levels of control in the building plant, and limited controls in place and operational in the building. Summary of the controls is as follows:

- A portion of the existing central plant controls are of previous generation, and to some extent in dis-repair. There is limited functional automation for simple matters of valve actuation, pump speed control, re-set and optimization capability, and interface to connected loads. This condition results in supervisory requirements by manual means, or operation of the plant with limited means for monitoring during off-hours or on weekends. There is functional flow metering at the central plant, by which plant load is calculated (in tons). The accuracy of these devices is uncertain.

The pneumatic controls are in need of comprehensive re-vitalization and recommended to be upgraded to Digital Direct Controls (DDC).

4.0 Building Recommendations

IV - ALTERNATIVES FOR MODIFICATIONS, UPGRADES, AND SYSTEM DESIGN

In order to accommodate connection of additional loads to the existing central chiller plant, multiple pursuits are considered in this evaluation, as follows:

- Implement upgrades and modifications to the central plant
 - Replace Cooling towers which show excessive corrosive wear
 - Review and implement new chemical treatment of plant
 - Replace existing Centrifugal Chiller (CH-2)
 - option to replace with Turbocor Chiller
 - Evaluate Thermal ICE Storage system and recommission to
- Option to connect existing plant to Campus Central Plant loop - Provide building Secondary Booster pumps
- Identify opportunities for increase in capacity of SCHW distribution of campus central plant pumps
- Implement upgrades and modifications to the existing building HVAC services; upgrade all pneumatic controls with DDC.

Building 2 Plant Upgrades:

Alternatives which entail upgrades and modifications to the central plant to accommodate these requirements are as follows:

- **CP Scheme 1:** Upgrade the central plant Cooling Towers, Chillers and associated pumps to accommodate pumping capacity to incorporate building 2 into the main central plant chilled water loop. Upgrade associated primary CHW (and CW pumps), and cooling tower capacities, and electrical services as necessary. It would also be proposed to upgrade the building chiller plant DDC as part of this effort. Based on preliminary evaluation, it would be possible to implement upgrades within the central plant, but with ramifications as noted. Distribution beyond the current GPM capacity from the central plant would impose on SCHW pumping capacity for the existing loop configuration, and would dictate modifications to the existing SCHW distribution within the central plant, as well as to the loop itself.

Cost: To Be Determined.

Advantages: This measure would develop appropriate balance of cooling capacity, PCHW flowrates, and SCHW flowrates.

Disadvantages: The large chillers may offer poor part-load performance for low-loads encountered, and diminishes redundancy. Disruption to the central plant service would be significant. (Possible solution would be to provide Chillers with compressors based on the Turbocor technology.)

Building HVAC Systems:

There is legitimate consideration by which no modifications to existing buildings would be implemented, either as deferred maintenance ,or in the course of associated building renovation for areas untouched by the renovation. Specific terms are as follows:

- **Bldg Scheme 1:** Maintain existing building HVAC services. Exercise available plant, primary pumping, and secondary pumping capacities as available. Secondary Booster pump should be explored when implementing this scheme. A secondary booster pump will be installed at Building 2 to provide chilled water services to the building. This will keep the existing system, but utilize the exiting building plant as back up. It is recommended that the controls and cooling towers be replaced and the chillers be refurbished.
- **Bldg Scheme 2:** System Modifications and Upgrades: Re-fit existing services with improved temperature controls at the CHW control valve (to include flow-limiting devices - i.e. "Griswold's"), throughout the occupied spaces, and for economizer control operation. Ensure flexibility in valve replacements for extended range of CHW flows to accommodate diminished performance of equipment or excessive loads as is encountered on this campus.

Summary of Upgrades / Assignment of Preferences:

These measures are summarized and re-stated in Table 2, as follows:

Central Plant / Building HVAC Upgrades	
Order of Preference	Summary of Upgrade
1	CP Scheme 1: Replace existing water cooled plant components; integrate into existing central loop.
2	Bldg Scheme 1: Maintain Existing Building HVAC Systems
3	Bldg Scheme 2: Upgrade Existing Building HVAC Systems

Table 2

Preferences are presented to implement recommended upgrades to the campus chilled water plant and SCHW distribution, and to building HVAC systems.

V - RECOMMENDATIONS

Following are recommendations for implementation which the College may as deemed necessary, based on progressions of campus build-out and on-going assessment of the central chiller plant performance.

Central Plant Upgrades:

Based on the analysis the following modifications and upgrades are recommended for implementation to the central chiller plant and SCHW distribution:

- Expand central chiller plant as identified in CP Scheme 1
- Or Replace existing building chiller components with new equipment and development of the plants as a Distributed Central plant to contribute to the campus chilled water system.

Building HVAC Systems:

Based on the demonstrated performance of the central chiller plant and connected loads, and recognizing the financial constraints of the College, the following modifications and upgrades are recommended for implementation to building HVAC systems:

- Develop high-performance HVAC systems in new buildings, and similar measures in systems subject to re-model and refurbishment.
- Upgrade existing building HVAC systems as campus-wide performance is deemed deficient, as identified .

MECHANICAL COOLING PLANT UPGRADES

Options for cooling plant Upgrades at Building 2 were studied. The options studied are listed in Table 1 below:

Table 1 Description of Cooling Plant Alternatives

Alternative	Description	Installed Tonnage
Alternate #1 -Base Case Refurbish	Refurbish with same type of compressor, tower, etc.	280
Alternate #2 - Replace In Kind Match Load	Provide new cooling equipment to match calculated load, using most efficient equipment.	280 Ton chillers; 600 ton (2-Cell Tower)
Alternate #3 - Central Plant, Chilled Water Thermal Storage, Water Cooled Chillers	Water cooled central plant with refurbishment to ICE thermal storage.	1- 280 ton water cooled chiller, 9,800 ton-hour storage tank

Based on the issues considered, we would either recommend either Alternate 2 (Replace in Kind) or Alternate 3 (water cooled central plant with chilled water storage). Alternate 2 has the lowest life cycle cost compared to the other options, the best return on investment, and the shortest simple payback. However, it is worth considering the thermal storage alternate (Alternate 3) so the campus is positioned to handle long term on-peak utility rate escalation that could occur. The following table gives a brief financial summary of the recommendations above.

Alternate	First Cost (\$) (Including Soft Costs)	Operating Cost (\$)
Base Case - Refurbish	\$200,000	\$90,000 *
Alternate #2 - Water Cooled Central Plant	\$643,300	\$51,000
Alternate #3 - Water Cooled Central Plant and Chilled Water Thermal Storage	\$800,00	\$75,000

*Operational cost increased due to probably persistent calls for repairs on equipment.

MT SAC BUILDING 2 ROM
P2S # J5678



Estimated by: BT
 Checked by:
 Revision:
 Date: 5/21/2010

Item	Description	Quan	Unit	Material/Equipment		Labor			Equipment		Total Cost
				Unit \$	Total	MH/Unit	MH	Total	Rate	Total	

DIVISION 15 - Mechanical

Equipment

1	Chiller - (280 ton centrifugal) Centrifugal Chiller	1	Each	143000	\$143000.	290	290.0	\$27550.			\$170,550.
2	End Suction Pump System (Means D3020 330) End Suction Pumps	4	Each	12000	\$48000.	50	200.0	\$19000.			\$67,000.
3	Cooling Tower (2-Cell 600 tons) Cooling Towers - Full Stainless Steel	1	Each	102500	\$125000.	225	225.0	\$21375.			\$146,375.

Piping

1	Central Plant Piping 4" CHWS/R	1100	L.F.	30	\$33000.	0.7	770.0	\$73150.			\$106,150.
	Piping Fittings	50	Each	6	\$300.	0.40625	20.3	\$1930.			\$2,230.
	Piping Insulation	1100	L.F.	0.9	\$990.	0.046125	50.7	\$4820.			\$5,810.
	Couplings & Hangers	50	Each	5.4	\$270.	0.07875	3.9	\$374.			\$644.

Direct Digital Controls

Direct Digital Controls	1	L.S.	50000	\$50000.							\$50,000.
Testing Adjusting & Balancing	1	L.S.	10000	\$10000.							\$10,000.

Subtotal Mechanical				\$410,560.				\$148,199.			\$558,759.
Sales Tax	9.25%			\$37,977.							\$28,687.
OH & P	10.0%										\$55,876.

OPINION OF TOTAL PROBABLE COST

\$643,300.

This opinion of probable cost is approximate. Actual construction bids may vary significantly from this statement of probable costs due to timing of construction, changed conditions, labor rate changes or other factors beyond the control of P2S Engineering, Inc.

EXHIBIT A

EXISTING EQUIPMENT SCHEDULE

WATER COOLED CHILLERS

MARK NO.	SERVICE	LOCATION	NOMINAL CAPACITY (TONS)	COMPRESSOR DATA			EVAPORATOR DATA					CONDENSER DATA					ISOLATION DATA			OPERATING WEIGHT LBS	REMARKS
				MAX KW	VOLTS	PHASE	EWT (F)	LWT (F)	GPM	MAX PD (FT)	FOULING FACTOR	EWT (F)	LWT (F)	GPM	MAX PD (FT)	FOULING FACTOR	MOUNT TYPE	DEFL (IN)	BASE TYPE		
CH-1	BLDG 2	BLDG 2 MECH RM	150	107	460	3	60	44	247	12	.00025	85	95	443	20	.00025	B	2.0	B-1	7000	TRANE RTHB R22 ICE MAKING
CH-2	BLDG 2	BLDG 2 MECH RM	280	128	460	3	60	44	300	8.65	.00025	85	95	600	17.37	.00025	B	2.0	B-1	15000	TRANE RTHB R22 ICE MAKING

COOLING TOWERS

MARK NO.	SERVICE	LOCATION	TYPE	DESIGN WET BULB (F)	NO OF CELLS	CONDENSER DATA			FAN MOTOR DATA				ISOLATION DATA			OPERATING WEIGHT LBS	REMARKS
						EWT (F)	LWT (F)	GPM	HP	RPM	VOLT	PH	MOUNT TYPE	DEFL (IN)	BASE TYPE		
CT-1	CH-1, CH-2	CENTRAL PLANT	FORCED DRAFT COUNTER FLOW	74	2	95	85	600	20	N/A	460	3	B	3.0	B-4	10000	EQUAL TO BAD MODEL VTL-152M, PROVIDE 5 HP PONY MOTOR
CT-2	CH-1, CH-2	CENTRAL PLANT	FORCED DRAFT COUNTER FLOW	74	2	95	85	600	20	N/A	460	3	B	3.0	B-4	10000	EQUAL TO BAD MODEL VTL-152M, PROVIDE 5 HP PONY MOTOR

PUMPS

MARK NO.	SERVICE	LOCATION	TYPE	PERFORMANCE DATA						MOTOR			ISOLATION DATA			OPERATING WEIGHT W/D BASE (LBS)	REMARKS
				GPM	TDH (FT)	NPSHR (FT)	DESIGN (PSIA)	MAX BHP	RMP	HP	VOLT	PHASE	MOUNT TYPE	DEFL (IN)	BASE TYPE		
CHWP-1	CHILLED WATER	CENTRAL PLANT	END SUCTION	300	85		150		1750	20	460	3	B	2.5000	B-2	590	-
CHWP-2	CHILLED WATER	CENTRAL PLANT	END SUCTION	300	85		150		1750	20	460	3	B	2.5000	B-2	590	-
CWP-1	CONDENSER	CENTRAL PLANT	END SUCTION	600	75		150		1750	30	460	3	B	2.5000	B-2	750	DESIGN FOR OUT DOOR USE
CWP-2	CONDENSER	CENTRAL PLANT	END SUCTION	600	75		150		1750	30	460	3	B	2.5000	B-2	750	DESIGN FOR OUT DOOR USE
HWP-1	HOT WATER	CENTRAL PLANT	END SUCTION	75	65		150		1750	5	460	3	B	2.0000	B-2	350	DESIGN FOR OUT DOOR USE
HWP-2	HOT WATER	CENTRAL PLANT	END SUCTION	75	65		150		1750	5	460	3	B	2.0000	B-2	350	DESIGN FOR OUT DOOR USE

EXISTING EQUIPMENT

EXHIBIT B

EXISTING EQUIPMENT DATA

ORDER NAME	BL REV	ORDER TYPE	BUSINESS UNIT	S	PCODE
W2E977A	A 1	Sales Order	LAX LAX La Crosse	N	0347
VAL-DATE	PIC-DATE	FEED MFG-DATE	BACKWARD DATE	TAG	
04/05/1995 00:00	04/05/1995 00:00	04/05/1995 00:00			

>>>> GENERAL <<<<

Business Unit	Order	B/L	RV	Kodiak Stat	PGRP	Qty	Val	Pick	Spcl	SN	Mfg Ord Status
LAX LAX La Crosse	W2E977A	A	1		CV10	1			<input type="checkbox"/>	<input checked="" type="checkbox"/>	AO
PCOD	Type	Master Drawing	Short Model #:	Lynx SO Number	Lynx SO Status	Ship Status					
0347	SO					SHPD					

	Status	Date	Requested By	Date	By
Validate:	<input type="checkbox"/> Complete	04/05/1995 00:00		Added: 10/12/1994 00:00	AADS
Pick Parts:	<input type="checkbox"/> Complete	04/05/1995 00:00		Changed: 04/05/1995 00:00	LAKAB
Mfg File:	<input type="checkbox"/> Complete	04/05/1995 00:00		Shipped: 7/13/1995 00:00	
Spec File:	<input type="checkbox"/> Complete	04/05/1995 00:00			

Service Model Number
 ----+----1-----2-----3-----4-----5-----6-----7-----8
 CVHE028FA2DO3UE2253E1E3HBC0000000LABF00000

Header Card Image
 ----+----1-----2-----3-----4-----5-----6-----7-----8-----9-----0
 1CVHE028M 000013471W2E977AA

System: PDS2 Source: SOURCE_HISTORY

ORDER NAME W2E977A	BL REV A 1	ORDER TYPE Sales Order	BUSINESS UNIT LAX LAX La Crosse	S PCODE N 0347
VAL-DATE 04/05/1995 00:00	PIC-DATE 04/05/1995 00:00	FEED MFG-DATE 04/05/1995 00:00	BACKWARD DATE	TAG

>>>> PCB DETAILS <<<<<

POS	COIL	SEQ	PRODUCT GROUP	QTY	HEADER TYPE	PROD CODE
		0		AA	0	1
TYPE	RUL	CATG	CODE	SPC	DESCRIPTION	
FCAT	S	MODL	CVHE		CENTRAVAC - 3 STAGE COMPRESSOR	
FCAT	S	DSEQ	2D		RELOCATE OIL TANK CHARGE VALVE	
FCAT	S	NTON	280		280 NOMINAL TON UNIT	
FCAT	S	VOLT	460		460 VOLT UNIT	
FCAT	S	HRTZ	60		60 HERTZ UNIT	
FCAT	S	TYPE	SNGL		SINGLE CONDENSER COOLING ONLY	
FCAT	S	TYPO	STD		STANDARD SHELLS	
FCAT	S	CPKW	142		COMPRESSOR MOTOR KW	
FCAT	S	CPIM	225		Impeller cutback	
FCAT	S	EVTM	IECU		INTERNAL ENHANCE CU EVAP TUBES	
FCAT	S	EVTH	28		.028 EVAP TUBE WALL THICKNESS	
FCAT	S	EVSZ	032S		320 SHORT EVAP SHELL SIZE	
FCAT	S	EVBS	200		200 TON EVAP TUBE BUNDLE	
FCAT	S	EVWC	STD		STANDARD EVAP WTRBOX	
FCAT	S	EVWP	2		2 PASS EVAP WATERBOX	
FCAT	S	EVWT	NMAR		NON MARINE EVAP WATERBOX	
FCAT	S	EVPR	150		150 PSI EVAP WTR SIDE PRESSURE	
FCAT	S	EVCO	VICT		VICTAULIC EVAP CONNECTION	
FCAT	S	EVWA	LELE		IN LH END OUT LH END	
FCAT	S	CDTM	TECU		INTERNAL ENHANCED .75 CU TUBE	
FCAT	S	CDTH	28		.028 COND TUBE WALL THICKNESS	
FCAT	S	CDSZ	032S		320 TON SHORT COND SHELL	
FCAT	S	CDBS	280		280 TON COND TUBE BUNDLE	
FCAT	S	CDWC	STD		STD WELDED COND WTRBOX CONST	
FCAT	S	CDWP	2		2 PASS COND WATERBOX	
FCAT	S	CDWT	NMAR		NON-MARINE WATERBOX TYPE COND	
FCAT	S	CDPR	150		150 PSI COND WTR SIDE PRESSURE	
FCAT	S	CDCO	VICT		VICTAULIC COND WTRBOX CONN	
FCAT	S	CDWA	LELE		IN LH END OUT LH END COND	
FCAT	S	CDTY	STD		STD COND CONSTR REFRIG SIDE	
FCAT	S	TSTY	STD		STANDARD Tube Sheet Construction	
FCAT	O	ECTY	WEOR		WELDED ECONOMIZER ORIFICE	
FCAT	S	ORSZ	250		ORIFICE SIZE	
FCAT	S	PURG	PURE		PURIFIER PURGE(INCL.NZEP PURG)	
FCAT	S	SPKG	DOM		DOMESTIC Shipping Package	
FCAT	O	OPTI	INSL		INSULATION PACKAGE	
FCAT	S	HGBP	WO		WITHOUT HOT GAS BY-PASS	
FCAT	S	AGLT	UL		UL LISTED UNIT	
FCAT	S	CNIF	UCP2		MICRO PROCESSOR 2ND GENERATION	
FCAT	M	COPT	OPTM		OPTIONS MODULE	
FCAT	M	COPT	BRTS		BEARING OIL TEMPERATURE	
FCAT	M	COPT	WVUO		PHASE VOLTAGE SENSER	
FCAT	S	SRTY	RSTR		REMOTE MOUNTED STAR DELTA	
FCAT	O	SRRL	207		MAX STARTER RLA	
FCAT	O	PNCO	DISC		DISCONNECT SWITCH	
FCAT	M	SROP	CLCA		CALIFORNIA CODE & UL	
FCAT	M	SROP	UL		REMOTE MOUNTED U.L. STARTER	
FCAT	S	EFLD	WATE		FLUID TYPE - WATER	
FCAT	S	CFLD	WATE		FLUID TYPE - WATER	
FCAT	S	TEST	AIR		STANDARD AIR RUN	
FCAT	S	REFG	123		REFRIGERANT TYPE = HCFC-123	
VCAT	S	NMKW	128		NAMEPLATE KW	
VCAT	S	NMRA	177		NAMEPLATE RLA	
VCAT	O	NMLA	1392		NAMEPLATE LRA	
VCAT	S	PTON	200		TONS OF REFRIGERATION - PRIM	

ORDER NAME W2E977A	BL REV A 1	ORDER TYPE Sales Order	BUSINESS UNIT LAX LAX La Crosse	S PCODE N 0347
VAL-DATE 04/05/1995 00:00	PIC-DATE 04/05/1995 00:00	FEED MFG-DATE 04/05/1995 00:00	BACKWARD DATE	TAG

>>>> PCB DETAILS <<<<

TYPE	RUL	CATG	CODE	SPC	DESCRIPTION
VCAT	S	PCKW	128		PERFORMANCE KW - PRIM
VCAT	S	PRLA	177		RATED LOAD AMP - PRIM
VCAT	S	PTIE	60		EVAP ENTERING WTR TEMP - PRIM
VCAT	S	PTOE	44		EVAP LEAVING WTR TEMP - PRIM
VCAT	S	PGME	300		EVAP GAL PER MINUTE - PRIM
VCAT	S	PPDE	8.65		EVAP PRESSURE DROP - PRIM
VCAT	S	PFFE	.00025		EVAP FOULING FACTOR - PRIM
VCAT	S	ECON	0		EVAPORATOR FLUID CONCENTRATION
VCAT	S	PTIC	85		COND ENTERING WTR TEMP - PRIM
VCAT	S	PTOC	94.51		COND LEAVING WTR TEMP - PRIM
VCAT	S	PGMC	600		COND GAL PER MINUTE - PRIM
VCAT	S	PPDC	17.37		COND PRESSURE DROP - PRIM
VCAT	S	PFFC	.00025		COND FOULING FACTOR - PRIM
VCAT	S	CCON	0		COND FLUID CONCENTRATN - PRIM
VCAT	S	REVL	55017		SELECTED CODE REV LEVEL

POS	COIL	SEQ	PRODUCT GROUP	QTY	HEADER TYPE	PROD CODE
		2		AA	0	1

TYPE	RUL	CATG	CODE	SPC	DESCRIPTION
FCAT	S	MODL	CVCA		CENTRAVAC COMPRESSOR - 3 STAGE
FCAT	S	DSEQ	H0		RELOCATE OIL TANK CHARGE VALVE
FCAT	S	NTON	280		280 NOMINAL TON COMPR
FCAT	S	VOLT	460		460 VOLT COMPRESSOR
FCAT	S	HRTZ	60		60 HERTZ COMPRESSOR
FCAT	S	TYPE	SP		FACTORY - MTD ON CTV SHELLS
FCAT	S	CPKW	142		COMPRESSOR MOTOR KW
FCAT	S	CPIM	225		22.5 22.5 22.5
FCAT	S	DSCH	D180		VOLUTE DISCHARGE ANGLE
VCAT	O	NMRA	177		NAMEPLATE RLA
VCAT	O	NMKW	128		NAMEPLATE KW

ORDER NAME W2E977A	BL REV A 1	ORDER TYPE Sales Order	BUSINESS UNIT LAX LAX La Crosse	S PCODE N 0347
VAL-DATE 04/05/1995 00:00	PIC-DATE 04/05/1995 00:00	FEED MFG-DATE 04/05/1995 00:00	BACKWARD DATE	TAG

>>>> PCB DETAILS <<<<<

POS	COIL	SEQ	PRODUCT GROUP	QTY	HEADER TYPE	PROD CODE
		3		AA	0	1
TYPE	RUL	CATG	CODE	SPC	DESCRIPTION	
FCAT	S	MODL	SHEL		CENTRAVAC SHELLS	
FCAT	S	CPSZ	032		230-320 NTON COMPR (CVHE)	
FCAT	S	TYPE	SNGL		SINGLE CONDENSER COOLING ONLY	
FCAT	S	TYPO	STD		STANDARD SHELLS	
FCAT	S	EVSZ	032S		320 SHORT EVAP SHELL SIZE	
FCAT	S	EVTM	IECU		1.00 INTERNAL ENHANCE CU EVAP TUBES	
FCAT	S	EVTH	28		.028 EVAP TUBE WALL THICKNESS	
FCAT	S	EVBS	200		200 TON EVAP TUBE BUNDLE	
FCAT	S	EVWC	STD		STANDARD EVAP WTRBOX	
FCAT	S	EVWT	NMAR		NON MARINE EVAP WATERBOX	
FCAT	S	EVPR	150		150 PSI EVAP WTR SIDE PRESSURE	
FCAT	S	CDSZ	032S		320 TON SHORT COND SHELL	
FCAT	S	CDTM	TECU		INTERNAL ENHANCED .75 CU TUBE	
FCAT	S	CDTH	28		.028 COND TUBE WALL THICKNESS	
FCAT	S	CDBS	280		280 TON COND TUBE BUNDLE	
FCAT	S	CDWC	STD		STD WELDED COND WTRBOX CONST	
FCAT	S	CDWT	NMAR		NON-MARINE WATERBOX TYPE COND	
FCAT	S	CDPR	150		150 PSI COND WTR SIDE PRESSURE	
FCAT	S	CDTY	STD		STD COND CONSTR REFRIG SIDE	
FCAT	S	TSTY	STD		STANDARD	
FCAT	O	ECTY	WEOR		WELDED ECONOMIZER ORIFICE	
FCAT	S	HGBP	WO		WITHOUT HOT GAS BY-PASS	
FCAT	S	ORSZ	250		ORIFICE SIZE	

POS	COIL	SEQ	PRODUCT GROUP	QTY	HEADER TYPE	PROD CODE
		4		AA	0	1
TYPE	RUL	CATG	CODE	SPC	DESCRIPTION	
FCAT	S	MODL	WTBX		CENTRAVAC WATER BOXES	
FCAT	S	EVSZ	032S		320 SHORT EVAP SHELL SIZE	
FCAT	S	EVTU	1.00		1.00 TUBE DIAMETER	
FCAT	S	EVWC	STD		STANDARD EVAP WTRBOX	
FCAT	S	EVWT	NMAR		NON MARINE EVAP WATERBOX	
FCAT	S	EVPR	150		150 PSI EVAP WTR SIDE PRESSURE	
FCAT	S	EVWP	2		2 PASS EVAP WATERBOX	
FCAT	S	EVWA	LELE		IN LH END OUT LH END	
FCAT	S	EVCO	VICT		VICTAULIC EVAP CONNECTION	
FCAT	S	CDSZ	032S		320 TON SHORT COND SHELL	
FCAT	S	CDWC	STD		STD WELDED COND WTRBOX CONST	
FCAT	S	CDWT	NMAR		NON-MARINE WATERBOX TYPE COND	
FCAT	S	CDPR	150		150 PSI COND WTR SIDE PRESSURE	
FCAT	S	CDWP	2		2 PASS COND WATERBOX	
FCAT	S	CDWA	LELE		IN LH END OUT LH END COND	
FCAT	S	CDCO	VICT		VICTAULIC COND WTRBOX CONN	

ORDER NAME W2E977A	BL REV A 1	ORDER TYPE Sales Order	BUSINESS UNIT LAX LAX La Crosse	S PCODE N 0347
VAL-DATE 04/05/1995 00:00	PIC-DATE 04/05/1995 00:00	FEED MFG-DATE 04/05/1995 00:00	BACKWARD DATE	TAG

>>>> PCB DETAILS <<<<

POS	COIL	SEQ	PRODUCT GROUP	QTY	HEADER TYPE	PROD CODE
		5		AA	0	1
TYPE	RUL	CATG	CODE	SPC	DESCRIPTION	
FCAT	S	MODL	CVRA		CENTRAVAC CONTROL SYSTEM	
FCAT	O	DSEQ	A		UCP2 ORIGINAL DESIGN (CVRB)	
FCAT	S	VOLT	460		460 VOLT UNIT	
FCAT	S	HRTZ	60		60 HERTZ UNIT	
FCAT	S	TYPE	CVH		CENTRAVAC - PRESENT PROD	
FCAT	S	CNIF	UCP2		MICRO PROCESSOR 2ND GENERATION	
FCAT	M	COPT	OPTM		OPTIONS MODULE	
FCAT	M	COPT	BRTS		BEARING OIL TEMPERATURE	
FCAT	M	COPT	WVUO		WATT/PF/VOLT/UNDER OVER PROTEC	
FCAT	S	SRTY	RSTR		STAR DELTA	
FCAT	O	PURG	PURE		PURIFIER PURGE	
FCAT	O	AGLT	UL		UL LISTED UNIT	
VCAT	O	NMKW	128		NAMEPLATE KW	
VCAT	O	NMRA	177		NAMEPLATE RLA	
VCAT	O	PTIE	60		EVAP ENTERING WTR TEMP - PRIM	
VCAT	O	PTOE	44		EVAP LEAVING WTR TEMP - PRIM	

POS	COIL	SEQ	PRODUCT GROUP	QTY	HEADER TYPE	PROD CODE
		6		AA	0	1
TYPE	RUL	CATG	CODE	SPC	DESCRIPTION	
FCAT	S	MODL	ASSY		CENTRAVAC ASSEMBLIES	
FCAT	S	TYPE	SNGL		SINGLE CONDENSER COOLING ONLY	
FCAT	S	TYPO	STD		STANDARD SHELLS	
FCAT	S	CPSZ	032		230-320 NTON COMPR (CVHE)	
FCAT	S	EVSZ	032S		320 SHORT EVAP SHELL SIZE	
FCAT	S	EVPR	150		150 PSI EVAP WTR SIDE PRESSURE	
FCAT	S	EVWC	STD		STANDARD EVAP WTRBOX	
FCAT	S	CDSZ	032S		320 TON SHORT COND SHELL	
FCAT	S	CDPR	150		150 PSI COND WTR SIDE PRESSURE	
FCAT	S	CDWC	STD		STD WELDED COND WTRBOX CONST	
FCAT	S	CDTY	STD		STD COND CONSTR REFRIG SIDE	
FCAT	O	ECTY	WEOR		WELDED ECONOMIZER ORIFICE	
FCAT	S	HGBP	WO		WITHOUT HOT GAS BY-PASS	
FCAT	S	PURG	PURE		PURIFIER PURGE	
FCAT	S	ORSZ	250		ORIFICE SIZE	
FCAT	S	FRAM	360		RELIANCE MTR FRAME SIZE	
FCAT	S	SRTY	RSTR		REMOTE MOUNTED STAR DELTA	
FCAT	O	SRRL	207		MAX RLA = 207	
FCAT	S	AGLT	UL		UL LISTED	
FCAT	S	HRTZ	60		60 HERTZ UNIT	

ORDER NAME W2E977A	BL REV A 1	ORDER TYPE Sales Order	BUSINESS UNIT LAX LAX La Crosse	S PCODE N 0347
VAL-DATE 04/05/1995 00:00	PIC-DATE 04/05/1995 00:00	FEED MFG-DATE 04/05/1995 00:00	BACKWARD DATE	TAG

>>>> PCB DETAILS <<<<

POS	COIL	SEQ	PRODUCT GROUP	QTY	HEADER TYPE	PROD CODE
		8		AA	0	1
TYPE	RUL	CATG	CODE	SPC	DESCRIPTION	
FCAT	S	MODL	CVSF		CENTRAVAC - STARTER FOR UCP2	
FCAT	S	DSEQ	A		ADD SIZE 6 STARTER	
FCAT	S	VOLT	460		460 VOLT STARTER	
FCAT	S	HRTZ	60		60 HERTZ UNIT	
FCAT	S	AGLT	UL		UL LISTED UNIT	
FCAT	S	SRTY	RSTR		REMOTE MOUNTED STAR DELTA	
FCAT	O	SRRL	207		*** Not Found ***	
FCAT	S	PNCO	DISC		DISCONNECT SWITCH - NON FUSED	
FCAT	M	SROP	CLCA		CALIFORNIA CODE & UL	
FCAT	M	SROP	WVUO		WATT/PF/VOLT/UNDER OVER PROTEC	
VCAT	S	NMRA	177		NAMEPLATE RLA	
VCAT	S	NMKW	128		NAMEPLATE KW	

POS	COIL	SEQ	PRODUCT GROUP	QTY	HEADER TYPE	PROD CODE
		9		AA	0	1
TYPE	RUL	CATG	CODE	SPC	DESCRIPTION	
????		MODL	EMD		*** Not Found ***	
????		TYPE	CTV		*** Not Found ***	
FCAT	O	SRTY	RSTR		STAR DELTA	
FCAT	S	CNIF	UCP2		MICRO PROCESSOR 2ND GEN	
FCAT	M	COPT	OPTM		OPTIONS MODULE	

ORDER CHECK LIST

SALES ORDER # WA-F874
HA AO ✓ CRA ✓
MTO STOCK Q-CYCLE ✓
QTY 1 MODEL ETHB 150L 460/60

Date Order Received 5-23-95
Date Order In AOS 5-23-95
Date Order Released 5-23-95
Date Credit Approved 5-23-95

Requested Ship Date 7-10-95 NB
EST. Ship Date 7-17-95
Customer Acct. #
(Is it a Z1 Acct. # ?)

QSQ

SUBMITTAL
MATERIALS
CUST.SER.

 ✓
 ✓
 ✓

MATERIALS CHECK LIST

MO # 89.87RT150

Date Entered in M.S. 5-31-95
Completion Date 7/11 ~~7-10-95~~
BOM Created 6/9

SUBMITTAL CHECK LIST

Drawings 12
IOM'S 12

Date Mailed 6-4-95 NA

HA -- File
AO & Credit Hold --- File
AO & Credit Appr. --- Mat. Rep.

NOTES:

~~on hold for PO~~
503-04

ORDER INFORMATION SHEET — WORK SHEET

JOB TYPE: OIS JIS

Prime Salesman (SMAN Code): W2-D07			 TRANE™	Job No. W2-33062	
Job Name: Mt. Sac Performing Arts					
Job Location: Walnut, CA					
Owner:			FACTORY USE ONLY		
Architect:			Date Shipped	Bill of Lading No.	Invoice Date
Engineer: Syska & Hennessey			Order/Invoice No. UW2-F874		
Customer Account Number W2-18-0045-7	Customer P.O. Number 11747-337	Terms — Net 30 Days	Ship With		
Billing Method <input checked="" type="checkbox"/> Lump Sum <input type="checkbox"/> Net Ea. <input type="checkbox"/> List Disc.	Invoice Type <input checked="" type="checkbox"/> Reg. <input type="checkbox"/> Custom	No. Invoices 3	F.O.B. Pueblo, CO FAPPD	Order Date 5/22/95	
Order Class: A3JLAG2	ICS Job:		Ship Via Open Truck	Prepaid <input checked="" type="checkbox"/>	Collect <input type="checkbox"/>
Sold To Overland Mechanical 8345 Hayvenhurst Place Sepulveda, CA 91343			Ship To Overland Mechanical c/o Mt. Sac Performing Arts 1100 North Grand Walnut, CA		
Special Instructions			Mark Packages		

Mark BL — Call No: **818-891-0881** Attr: **Dennis** **48** Hrs. Before Delivery

ITEM	QTY.	DESCRIPTION	PRODUCT CODE	ORDER PRICING RECAP	
A	1	Model RTHB-150L	Q-Cycle	Total List — P/C 153	\$ 123,949
				*Quantity LPAF	x _____
				Quick Ship LPAF	x _____
				Regional LPAF	x _____
				Cost Point LPAF	x _____
				Adjusted List	\$ 123,949
				Multiplier	x .395
				Subtotal — P/C	\$ 48,960
				Total List — P/C	\$ _____
				*Quantity LPAF	x _____
Quick Ship LPAF	x _____				
Regional LPAF	x _____				
Cost Point LPAF	x _____				
Adjusted List	\$ _____				
Multiplier	x _____				
Subtotal — P/C	\$ _____				
*Requires Manual Override Of Qty. LPAF (Y/N) _____					
Net Amounts:					
Special Design	\$ _____				
Controls	\$ _____				
Extended Warranty	\$ _____				
Others	\$ 500				
Subtotal — Nets	\$ 500				
TOTAL BILLING PRICE				\$ 49,460	
Purchase Order Amount				\$ 139,000	

Entered	Ship Status: <input type="checkbox"/> HA (Hold For Approval) <input checked="" type="checkbox"/> AO (At Once)	Requested Ship Date 7/10/95 <input checked="" type="checkbox"/> Not Before	Prints No. 12	Service Lit. No. 12	Order Multiplier .395
Office	Los Angeles	Los Angeles	Los Angeles	Sales Order No. UW2-F874 Page 1 of 5	
Salesman	Don LaMarr	Blair Boyce	Doug Crumley		
Code: %	W2-D07-30	W2-D28-30	W2-D38-40		
Sale	49,460	14,838	19,784		
Commission	4,560	1,368	1,824		

Sales Office Complete This Section

Does P.O. Amount Include Tax? Yes No

If Yes, Tax \$'s on P.O. are \$ _____

Should Tax Be Invoiced? Yes No If No, X Proper Block Below

Blank Exemption Certificate Attached Exemption Included On P.O.

Job Exemption Certificate Attached Exemption On File In La Crossa

In date: 05/23/95 SPA Number:
 Data Drive & Path: N:\CDSPR...

File name: W2F874
 Price Sheet Used: 10/26/94

8987

RHB 150L 460/60/3
 +1

CAT	FCOD	Description	Unadjusted List	Net	+/-
0DL	RTHB	SERIES R CENTRAVAC	--INCLUDED--		
TON	150	150 NOMINAL TONS	87,885	500	
0LT	460A	460/60/3	--INCLUDED--		
NTY	ICEL	LOW TEMP ICE MAKING (39F-20F)	1,672	0	
LV	VS	WITH REFRIGERANT ISOLATION VALVES	2,816	0	
VLG	LONG	LONG LENGTH SHELLS	16,831	0	
PSH	NONE	NONE	0	0	
WP	3	3 PASS EVAPORATOR -NO \$ ADD-	0	0	
CO	LH	L.H. EVAP CONNECTIONS	--INCLUDED--		
PR	150	150 PSI EVAP WATER PRESS	0	0	
TM	IECU	INT. ENHANCED TUBES (STD)	0	0	
WP	2	2 PASS CONDENSER -NO \$ ADD-	0	0	
CO	LH	L.H. COND CONNECTIONS	--INCLUDED--		
PR	150	150 PSI COND WATER PRESS	0	0	
TM	IECU	INT. ENHANCED TUBES (STD)	0	0	
PKW	107	107 KW MOTOR (130 PACK STOCK)	--INCLUDED--		
RLA	207	207 MAX RLA U.M. OR REMOTE STR	0	0	
ALT	UL	UL	0	0	
TY	USTR	UNIT MTD - STAR DELTA	9,179	0	+2
CO	DISC	MECH DISCONNECT SWITCH	2,272	0	
PTI	NONE	NO UNDER/OVER VOLTAGE PROT.	--INCLUDED--		
VIF	MODU	OPTIONS MODULE	803	0	
MM	NONE	NO COMMUNICATIONS PACKAGE	0	0	
VAT	THRM	FACTORY INSULATION	2,491	0	
PKG	NONE	STANDARD - NO SKID	0	0	
VTT	NONE	NO PERFORMANCE TEST	0	0	

	Totals	List	Net
P/C 153	Total (Each):	\$ 123,949	\$ 500
	Quantity:	1	1
	Total (Ext):	\$ 123,949	\$ 500

Selection Totals

	List	Fap (0.395)	Cost Point (0.358)	Entered (1.000)
ane \$	123,949	48,960	44,374	123,949
ets \$	500	500	500	500
otal \$	124,449	49,460	44,874	124,449

----- Main Unit Model Number: RT01 -- Quantity: 1 -----

DDL-RTHB NTON-150 VOLT-460A UNTY-ICEL VLVS-WITH UNLG-LONG SPSH-NONE
 WWP-3 EVCO-LH EVPR-150 EDTM-IECU CDWP-2 CDCO-LH CDPR-150
 DTM-IECU CPKW-107 MRLA-207 AGLT-UL SRTY-USTR PNCO-DISC OPTI-NONE
 PKG-NONE CNIF-MODU COMM-NONE UNAT-THRM UNTT-NONE

Note: The following items are NOT included in the model number and MUST be ordered separately:

Total Qty	Description	Part No.
1	SERIES R CENTRAVAC	
1	LOW TEMP ICE MAKING (39F-20F)	

-----Performance Data-----
 File -----Description----- ---Value--- --Units-- Source

Unit Tag: CH-1 *Day Cond*

EQ	CAPACITY	154	TONS	PRODSEL
EQ	DESIGN KW	106	KW	PRODSEL
EQ	ENTERING EVAP. WATER TEMP.	60	DEG F	PRODSEL
EQ	LEAVING EVAP. WATER TEMP	44	DEG F	PRODSEL
EQ	EVAPORATOR FLOW	247	GPM	PRODSEL
PT	EVAPORATOR PERCENT GLYCOL	25	%	PRODSEL
EQ	EVAPORATOR PRESSURE DROP	12	FT H2O	PRODSEL
EQ	EVAPORATOR FOULING FACTOR	0.00025		PRODSEL
EQ	ENTERING COND. WATER TEMP.	85	DEG F	PRODSEL
EQ	LEAVING COND. WATER TEMP.	95	DEG F	PRODSEL
EQ	CONDENSER FLOW	443	GPM	PRODSEL
PT	CONDENSER PERCENT GLYCOL	0	%	PRODSEL
EQ	CONDENSER PRESSURE DROP	20	FT H2O	PRODSEL
EQ	CONDENSER FOULING FACTOR	0.00025		PRODSEL
EQ	NOMINAL MOTOR KW	107	KW	PRODSEL
EQ	MOTOR FULL LOAD AMPS	150	AMPS	PRODSEL
EQ	MOTOR LOCKED ROTOR AMPS	658	AMPS	PRODSEL
PT	SALES ORDER VOLTAGE	460	VOLTS	PRODSEL
EQ	FREQUENCY	60	HZ	PRODSEL
PT	EVAPORATOR ORIFICE	2509		PRODSEL
PT	CONDENSER ORIFICE	1808		PRODSEL
PT	EVAPORATOR PRESSURE SWITCH	11.4		PRODSEL
EQ	COMPRESSOR RATIO	1		PRODSEL

----- Main Unit () Model Number: RT01 --- Quantity: 1 -----

DDL-RTHB NTON-150 VOLT-460A UNTY-ICEL VLVS-WITH UNLG-LONG SPSH-NONE
 WWP-3 EVCO-LH EVPR-150 EDTM-IECU CDWP-2 CDCO-LH CDPR-150
 JTM-IECU CPKW-107 MRLA-207 AGLT-UL SRTY-USTR PNCO-DISC OPTI-NONE
 PKG-NONE CNIF-MODU COMM-NONE UNAT-THRM UNTT-NONE

Note: The following items are NOT included in the model number and MUST be ordered separately:

Total Qty	Description	Part No.
1	SERIES R CENTRAVAC	
1	LOW TEMP ICE MAKING (39F-20F)	

-----Performance Data-----

Unit	Description	Value	Units	Source
Unit Tag: CH-1 ICE COND				
EQ	CAPACITY	105	TONS	USER
EQ	DESIGN KW	105	KW	USER
EQ	ENTERING EVAP. WATER TEMP.	37	DEG F	USER
EQ	LEAVING EVAP. WATER TEMP	26	DEG F	USER
EQ	EVAPORATOR FLOW	247	GPM	PRODSEL
PT	EVAPORATOR PERCENT GLYCOL	25	%	PRODSEL
EQ	EVAPORATOR PRESSURE DROP	13	FT H2O	USER
EQ	EVAPORATOR FOULING FACTOR	0.00025		PRODSEL
EQ	ENTERING COND. WATER TEMP.	85	DEG F	PRODSEL
EQ	LEAVING COND. WATER TEMP.	95	DEG F	PRODSEL
EQ	CONDENSER FLOW	324	GPM	USER
PT	CONDENSER PERCENT GLYCOL	0	%	PRODSEL
EQ	CONDENSER PRESSURE DROP	12	FT H2O	USER
EQ	CONDENSER FOULING FACTOR	0.00025		PRODSEL
EQ	NOMINAL MOTOR KW	107	KW	PRODSEL
EQ	MOTOR FULL LOAD AMPS	150	AMPS	PRODSEL
EQ	MOTOR LOCKED ROTOR AMPS	658	AMPS	PRODSEL
PT	SALES ORDER VOLTAGE	460	VOLTS	PRODSEL
EQ	FREQUENCY	60	HZ	PRODSEL
EQ	COMPRESSOR RATIO	1		PRODSEL

----- File Totals by Product Code -----

P/C	Totals	List	Net
P/C 153	Total (Avg Each):	\$ 123,949	\$ 500
	Quantity:	2	2
	Total (Ext):	\$ 247,898	\$ 1,000

TRANE SERIES R SELECTION PROGRAM

Version 14.08

Mon May 22, 1995

INPUT FILE NAME : C:\CUSTOMER\FTANDREW\MTSAC\RTHB.FRE
 PROJECT :
 LOCATION :
 BUILDING OWNER :
 PROGRAM USER :
 COMMENT :
 EPS FLAG : N

***** INPUT CONDITIONS *****

MACHINE TAG	CH-1	MOTOR KW SIZE	
COMPRESSOR SIZE	150	VOLTAGE	460
SHELL TYPE	LONG	FREQUENCY	60
DESIGN DUTY		MAX KW/TON	
DESIGN KW		REFRIGERANT	22
EXITING EVAP TEMP	26	ENTERING COND TEMP	85
EVAP FLOW RATE	247	COND FLOW RATE	
ENTERING EVAP TEMP		EXITING COND TEMP	95
EVAPORATOR PASSES	3	CONDENSER PASSES	2
EVAP FOULING FACTOR	0.00025	COND FOULING FACTOR	0.00025
MAX EV PRESSURE DROP		MAX CO PRESSURE DROP	
EVAP TUBE TYPE	STD	COND TUBE TYPE	STD
BUILT BY	PUEBLO	BRINE TYPE	
BRINE TYPE	EG	BRINE %	
BRINE %	25		

***** OUTPUT DATA *****

NOTE - RATING OUTSIDE THE SCOPE OF THE ARI CENTRIFUGAL AND
 ROTARY WATER CHILLERS CERTIFICATION PROGRAM.
 NOTE - LEAVING EVAP TEMP < 40.0 F MAY HAVE LIMITED UNLOADING,
 CONTACT PUEBLO MARKETING.

MODEL RTHB	150	SHELL LENGTH	LONG
DESIGN DUTY	105 TONS	POWER CONSUMED	105 KW
KW PER DESIGN DUTY	1.00		
EXIT EVAP TEMP	26.0 F	EXIT COND TEMP	95.0 F
ENTERING EVAP TEMP	37.0 F	ENTERING COND TEMP	85.0 F
EVAP FLOW RATE	247 GPM	COND FLOW RATE	324 GPM
EVAPORATOR PASSES	3	CONDENSER PASSES	2
EVAP PRESSURE DROP	13 FEET	COND PRESSURE DROP	12 FEET
EVAP FOULING FACTOR	0.00025	COND FOULING FACTOR	0.00025
EVAP BRINE TYPE	EG	COND BRINE TYPE	WATER
EVAP BRINE PERCENT	25	COND BRINE PERCENT	0
EVAP TUBE TYPE	STANDARD	COND TUBE TYPE	STANDARD
EVAP BRINE FREEZE PT	11.4 F		

NOMINAL MOTOR KW	107 KW	SHIP WEIGHT	5932 LBS
NOMINAL MOTOR LRA	658 AMPS	OPERATING WEIGHT	6364 LBS
RLA AT MOTOR KW	151 AMPS	REFRIGERANT CHARGE	380 LBS
RLA AT SELECTION KW	148 AMPS		

462-F874
 pg 4

TRANE SERIES R SELECTION PROGRAM

Version 14.08

Mon May 22, 1995

INPUT FILE NAME : C:\CUSTOMER\FTANDREW\MTSAC\RTHB.FRE
PROJECT :
LOCATION :
BUILDING OWNER :
PROGRAM USER :
COMMENT :
EPS FLAG : N

***** INPUT CONDITIONS *****

MACHINE TAG	CH-1	MOTOR KW SIZE	
COMPRESSOR SIZE	150	VOLTAGE	460
SHELL TYPE	LONG	FREQUENCY	60
DESIGN DUTY		MAX KW/TON	
DESIGN KW		REFRIGERANT	22
EXITING EVAP TEMP	44	ENTERING COND TEMP	85
EVAP FLOW RATE		COND FLOW RATE	
ENTERING EVAP TEMP	60	EXITING COND TEMP	95
EVAPORATOR PASSES	3	CONDENSER PASSES	2
EVAP FOULING FACTOR	0.00025	COND FOULING FACTOR	0.00025
MAX EV PRESSURE DROP		MAX CO PRESSURE DROP	
EVAP TUBE TYPE	STD	COND TUBE TYPE	STD
BUILT BY	PUEBLO	BRINE TYPE	
BRINE TYPE	EG	BRINE %	
BRINE %	25		

***** OUTPUT DATA *****

NOTE - RATING OUTSIDE THE SCOPE OF THE ARI CENTRIFUGAL AND ROTARY WATER CHILLERS CERTIFICATION PROGRAM.

MODEL RTHB	150	SHELL LENGTH	LONG
DESIGN DUTY	154 TONS	POWER CONSUMED	106 KW
KW PER DESIGN DUTY	0.69		

EXIT EVAP TEMP	44.0 F	EXIT COND TEMP	95.0 F
ENTERING EVAP TEMP	60.0 F	ENTERING COND TEMP	85.0 F
EVAP FLOW RATE	247 GPM	COND FLOW RATE	443 GPM
EVAPORATOR PASSES	3	CONDENSER PASSES	2
EVAP PRESSURE DROP	12 FEET	COND PRESSURE DROP	20 FEET
EVAP FOULING FACTOR	0.00025	COND FOULING FACTOR	0.00025
EVAP BRINE TYPE	EG	COND BRINE TYPE	WATER
EVAP BRINE PERCENT	25	COND BRINE PERCENT	0
EVAP TUBE TYPE	STANDARD	COND TUBE TYPE	STANDARD
EVAP BRINE FREEZE PT	11.4 F		

NOMINAL MOTOR KW	107 KW	SHIP WEIGHT	5932 LBS
NOMINAL MOTOR LRA	658 AMPS	OPERATING WEIGHT	6364 LBS
RLA AT MOTOR KW	151 AMPS	REFRIGERANT CHARGE	380 LBS
RLA AT SELECTION KW	150 AMPS		

UW2-F874
Pg 5

03/10/95

SERIES R --- ORDER ENTRY CHECKLIST

	YES	NO
LWTE not between 35 and 55 F	---	✓
LWTC not between 75 and 100 F	---	✓

If you answered YES to the above questions then look at the chart. If the points fall outside of the lines the order needs to go to engineering for review.

Delta T in condenser > 15 F	---	✓
Delta T in evaporator > 18 F	---	✓
Fouling factor > .001	---	✓
Delta T LWTE & LWTC < 25	---	✓
Solution is other than water, E.G. , P.G.	---	✓
Solution P.G. > 35 %	---	✓

NOTE: If you answered YES to any of the above list, the order must go to engineering for approval.

MISC: If RLA > 606 Amps	---	✓
Starter need to be remote mounted.	---	✓

Clear Language Display option	---	✓
Needs a remote CLD interface option. if there are multiple units on the order, only one unit needs a panel but each unit needs an interface module. Order Entry will delete extra panels off the EPS.		

PACKED STOCK ENTRY PROCEDURE

Obtain MO # from customer service	_____
EPS matches EPS book (especially RLA & LRA)	_____
Check for any NET ADDS	_____

MISC

If the unit is icemaking (ICEC, ICEP, ICEL) make sure the EPS has both daytime and icemaking conditions for the shop. If the unit is ICEC (daytime conditions above 40° F) or unit is ICEL (daytime conditions below 40° F) the unit needs an options module. ICEC needs no SEI. ICEL, ICEP do need if day ELWT < 40 F.

U.L. LIMITATIONS:

	YES	NO
Is the unit type ICEC, ICEL, ICEP, and the leaving EVP < 20	---	✓
Unit type has non - standard motor (the following are standard motor sizes)	---	✓

RTHB 130	107 kW, 121 kW	RTHB 255	197 kW, 226 kW
RTHB 150	121 kW, 107 kW	RTHB 300	226 kW, 197 kW
RTHB 180	145 kW, 166 kW	RTHB 380	277 kW, 324 kW
RTHB 215	166 kW, 145 kW	RTHB 450	324 kW, 277 kW

RLA Greater than 606 A	---	✓
Unit has design specials	---	✓

Design Specials: Please see Ann regarding any design specials that need to be U.L. listed. The order must go to engineering for SEI. Also need to get a design SPA from marketing engineers and include a copy of it in the file.

NOTE: If you answered YES to any of the above, the unit CANNOT be UL listed

SALES ORDER		62-F874						
STARTER								
PART #	DESCRIPTION	P.O. #		STAR DELTA				
571508070100	Y-DELTA 3DP BASE	P64229		SIZE MAX	MAX LOCKED ROTOR AMPS			
571508100100	Y-DELTA 3DP BASE W/DISC	P64232	X	RLA	208-240V	380-480V	550-600V	
571508130100	Y-DELTA 3DP BASE W/CB	P64235		3DP	207	1420	1420	909
				4DP	346	2598	2598	2078
571508080100	Y-DELTA 4DP BASE	P64230		5DP	606	4018	4018	3291
571508110100	Y-DELTA 4DP BASE W/DISC	P64233						
571508140100	Y-DELTA 4DP BASE W/CB	P64236						
571508090100	Y-DELTA 5DP BASE	P64231						
571508120100	Y-DELTA 5DP BASE W/DISC	P64234						
571508150100	Y-DELTA 5DP BASE W/CB	P64237						
571508160100	X-LINE 3DP BASE	P64238		ACROSS THE LINE				
571508190100	X-LINE 3DP BASE W/DISC	P64241		SIZE MAX	MAX LOCKED ROTOR AMPS			
571508220100	X-LINE 3DP BASE W/CB	P64244		RLA	208-240V	380-480V	550-600V	
				3DP	120	820	820	525
571508170100	X-LINE 4DP BASE	P64239		4DP	200	1500	1500	1200
571508200100	X-LINE 4DP BASE W/DISC	P64242		5DP	350	2320	2320	1900
571508230100	X-LINE 4DP BASE W/CB	P64245						
571508180100	X-LINE 5DP BASE	P64240						
571508210100	X-LINE 5DP BASE W/DISC	P64243						
571508240100	X-LINE 5DP BASE W/CB	P64246						
571508250100	UNDER/OVER VOLT PROT	P64247						
CONTROL PANEL								
PART #	DESCRIPTION	P.O. #		M.O. #S				
571508010100	BASE UNIT	P64131	X	8987KJ150				
571508020100	BASE W/MODU	P64132	X					
571508030100	BASE W/SUM	P64133						
571508040100	BASE W/TRC	P64134						
571508050100	BASE W/PIM	P64135						
571508060100	BASE W/CLDI	P64136						

L680001A L621198 0292 (2U014P 0018 95/05/23 1128

NON-COOL CHANGE ORDER

U W2-F874

LLACL08T

U W2-F874

W2-1B-0045-7

PAGE 1 OF 1

CD

W2-33062

SHIP FROM PBL

W2-D07

OVERLAND MECHANICAL

ORD:ENT 05/23/95 STAT ENTD 05/23/95 TYP QSQ PC 0153

ATTN: ANN

RELEASE FOR PRODUCTION. ✓

THANKS, DON LAMARR - LSA 5/23/95 DE

Done
5-23-95
af

TRANE

THE TRANE COMPANY 101 WILLIAM WHITE BLVD
 A DIVISION OF PUEBLO, CO 81001
 AMERICAN STANDARD

SUBMITTAL DATA
 CENTRAVAC HERMETIC WATER-COOLED
 ROTARY LIQUID CHILLER

ORDER DATE 05-23-95	TRANE SALES ORDER NO. W2-F874
------------------------	----------------------------------

JOB NAME MT. SAC PERFORMING ARTS	SOLD TO OVERLAND MECHANICAL
-------------------------------------	--------------------------------

ARCHITECT	ENGINEER SYSKA & HENNESSAY
-----------	-------------------------------

CUSTOMER ORDER NO. 11747-337	TRANE SALES OFFICE LOS ANGELES, CA	TRANE SALES ENGINEER DONALD R. LAMARR
---------------------------------	---------------------------------------	--

MODEL/SIZE RTHB 150	SHELL LENGTH LONG	TAG CH-1	QUANTITY 1
------------------------	----------------------	-------------	---------------

UNIT TYPE COOLING ONLY ICE MAKING LOW TEMP PROCESS X LOW TEMP ICE MAKING

DESIGN CONDITIONS DAYTIME CONDITIONS

TONS 154	KW 106	VOLTAGE 460/60	RLA 150	LRA 658
-------------	-----------	-------------------	------------	------------

	ENT F	LMT F	FLOW GPM	PRESSURE DROP FT	FOULING	TUBE TYPE	% GLYCOL	PASSES
EVAP	60	44	247	12	.00025	STD	25	3
COND	85	95	443	20	.00025	STD	0	2

EVAP	ENTERING CONNECTION	RIGHT	X LEFT	WATERSIDE PRESSURE	X 150	300
COND	ENTERING CONNECTION	RIGHT	X LEFT	WATERSIDE PRESSURE	X 150	300

COMPRESSOR MOTOR STARTER

STARTER DATA	X UNIT MOUNTED	REMOTE MOUNTED
TYPE	X STAR (WYE) DELTA	ACROSS-THE-LINE AUTO TRANSFORMER

STARTER ACCESSORIES:
 MECH DISCONNECT SWITCH

MICRO CONTROL PANEL	TRACER COMMUNICATIONS	SUMMIT COMMUNICATIONS
---------------------	-----------------------	-----------------------

UNIT ACCESSORIES:
 REFRIGERANT ISOLATION VALVES
 UL LISTED
 OPTIONS MODULE
 FACTORY INSULATION

APPROVAL STAMP

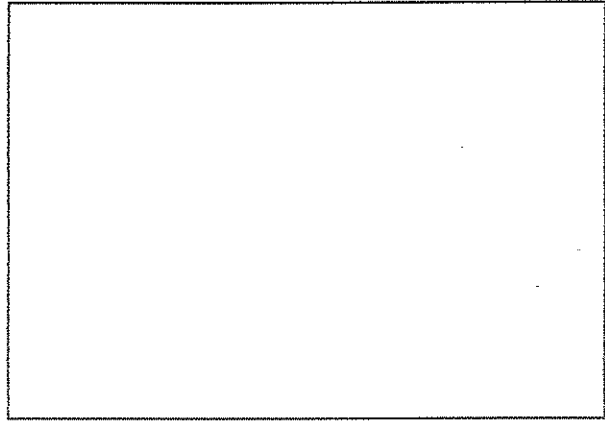

TRANE

THE TRANE COMPANY 101 WILLIAM WHITE BLVD
 A DIVISION OF PUEBLO, CO 81001
 AMERICAN STANDARD

SUBMITTAL DATA
 CENTRAVAC HERMETIC WATER-COOLED
 ROTARY LIQUID CHILLER

ORDER DATE 05-23-95	TRANE SALES ORDER NO. W2-F874
------------------------	----------------------------------

JOB NAME MT. SAC PERFORMING ARTS	SOLD TO OVERLAND MECHANICAL
-------------------------------------	--------------------------------

ARCHITECT	ENGINEER SYSKA & HENNESSAY
-----------	-------------------------------

CUSTOMER ORDER NO. 11747-337	TRANE SALES OFFICE LOS ANGELES, CA	TRANE SALES ENGINEER DONALD R. LAMARR
---------------------------------	---------------------------------------	--

MODEL/SIZE RTHB 150	SHELL LENGTH LONG	TAG CH-1	QUANTITY 1
------------------------	----------------------	-------------	---------------

UNIT TYPE COOLING ONLY ICE MAKING LOW TEMP PROCESS X LOW TEMP ICE MAKING

DESIGN CONDITIONS DAYTIME CONDITIONS

TONS 105	KW 105	VOLTAGE 460/60	RLA 150	LRA 658
-------------	-----------	-------------------	------------	------------

	ENT F	LWT F	FLOW GPM	PRESSURE DROP FT	FOULING	TUBE TYPE	% GLYCOL	PASSES
EVAP	37	26	247	13	.00025	STD	25	3
COND	85	95	324	12	.00025	STD	0	2

EVAP	ENTERING CONNECTION	RIGHT	X LEFT	WATERSIDE PRESSURE	X 150	300
COND	ENTERING CONNECTION	RIGHT	X LEFT	WATERSIDE PRESSURE	X 150	300

COMPRESSOR MOTOR STARTER

STARTER DATA	X UNIT MOUNTED	REMOTE MOUNTED	
TYPE	X STAR (WYE) DELTA	ACROSS-THE-LINE	AUTO TRANSFORMER

STARTER ACCESSORIES:
 MECH DISCONNECT SWITCH

MICRO CONTROL PANEL TRACER COMMUNICATIONS SUMMIT COMMUNICATIONS

UNIT ACCESSORIES:
 REFRIGERANT ISOLATION VALVES
 UL LISTED
 OPTIONS MODULE
 FACTORY INSULATION

APPROVAL STAMP

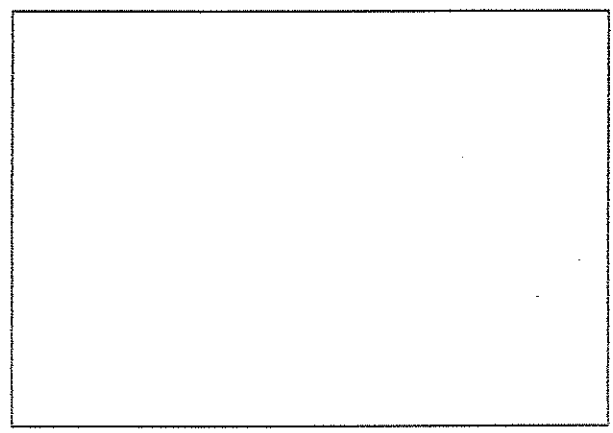

Series R - Ship History
Water Chiller Business Unit - Shipment Record Data Sheet

Part I - Final Assembly

Unit Serial Number: U 95608987
A N N A N N N N N

Unit Model No: R T H B 150FLCOOLWP000UNN3LF2LFV00U
A A A A N N N A A A A E A A E E E E A A A E A A E A A E E E E

Compressor Model Number: C H H A 140FA1DN107NNN
A A A A N N N A A A A N N N A A A

Compressor Serial Number: U 4568987
A A N A N N N N

Evaporator National Board Number: 34109
N N N N N

Condenser National Board Number: 34110
N N N N N

Starter Number: R T S B 0150FB011
A A A A N N N N A A E E E E E E E E A E

[] SEI [] SEI [] SEI [] SEI
NA N N N N NA N N N N NA N N N N NA N N N N

KEY: A -- Characters must be alpha. N -- Characters must be numeric.
E -- Characters may be either alpha or numeric. NA -- Not applicable to this unit.

SEE BACK PAGE FOR SHIP WITH ITEMS

SHIP HISTORY PART I COMPLETED BY: ART DATE 7-18-95

Part II - From Shipping Hardcopy

Sales Order Number: W2-F874 A

Ship Date: 7-18-95

Job Name: Mt. Sac Performing Arts

Series R - Ship History
Water Chiller Business Unit - Shipment Record Data Sheet

Part I (cont'd.) - Final Assembly

SHIP WITH ITEMS/WARRANTIES

- 5WAR 5 year Compressor warranty (Part No. 2705-4____-R4-00)
- INLS Spring Isolators (Part No. 5706-598__-0100)
- CLDP Remote CLD Panel
- CWRO CWR Outdoor Air Temp
- CLDI Remote CLD Interface Module
- PIM Printer Interface Module
- FS1 Flow Switch 150 psi NEMA 1 (Part No. X1304-0029-00) (circle 1 or 2)
- FS2 Flow Switch 300 psi NEMA 1 (Part No. X1347-0077-01) (circle 1 or 2)
- FS3 Flow Switch 150 psi vapor (Part No. X1347-0078-01) (circle 1 or 2)
- FS4 Flow Switch 300 psi vapor (Part No. X1366-0193-01) (circle 1 or 2)
- COOL Standard Cooling Only
- ICEC Standard Ice Making (X1379-0057-0900)
- ICEP Low Temp Process (39°F. to 20°F.)
- ICEL Low Temp Ice Making (39°F. to 20°F.)
- Separable shells
- Top hat
- Sound Attenuator

Other: _____

RTHB SUBMITTAL PICKLIST

MECHANICAL SPECIFICATIONS

RTHB-SM-0002 A

DIMENSIONAL DRAWING

PICK 1 OF THE NEXT 20

130/150 TON,	STD SHELLS,	UNIT MTD STARTER,	ALL VOLTAGES	RTHB-SU-1062 A
130/150 TON,	STD SHELLS,	REMOTE STARTER,	ALL VOLTAGES	RTHB-SU-1063 A
130/150 TON,	LONG SHELLS,	UNIT MTD STARTER,	ALL VOLTAGES	RTHB-SU-1064 A
130/150 TON,	LONG SHELLS,	REMOTE STARTER,	ALL VOLTAGES	RTHB-SU-1065 A
180/215 TON,	STD SHELLS,	UNIT MTD STARTER,	ALL VOLTAGES	RTHB-SU-1066 B
180/215 TON,	STD SHELLS,	REMOTE STARTER,	ALL VOLTAGES	RTHB-SU-1067 A
180/215 TON,	LONG SHELLS,	UNIT MTD STARTER,	ALL VOLTAGES	RTHB-SU-1068 A
180/215 TON,	LONG SHELLS,	REMOTE STARTER,	ALL VOLTAGES	RTHB-SU-1069 A
180/215 TON,	EXTD SHELLS,	UNIT MTD STARTER,	ALL VOLTAGES	RTHB-SU-1070 A
180/215 TON,	EXTD SHELLS,	REMOTE STARTER,	ALL VOLTAGES	RTHB-SU-1071 A
255/300 TON,	STD SHELLS,	UNIT MTD STARTER,	ALL VOLTAGES	RTHB-SU-1072 A
255/300 TON,	STD SHELLS,	REMOTE STARTER,	ALL VOLTAGES	RTHB-SU-1073 A
255/300 TON,	LONG SHELLS,	UNIT MTD STARTER,	ALL VOLTAGES	RTHB-SU-1074 A
255/300 TON,	LONG SHELLS,	REMOTE STARTER,	ALL VOLTAGES	RTHB-SU-1075 A
255/300 TON,	EXTD SHELLS,	UNIT MTD STARTER,	ALL VOLTAGES	RTHB-SU-1076 A **
255/300 TON,	EXTD SHELLS,	REMOTE STARTER,	ALL VOLTAGES	RTHB-SU-1077 A
380/450 TON,	STD SHELLS,	UNIT MTD STARTER,	ALL VOLTAGES	RTHB-SU-1078 A
380/450 TON,	LONG SHELLS,	UNIT MTD STARTER,	ALL VOLTAGES	RTHB-SU-1079 A
380/450 TON,	STD SHELLS,	REMOTE STARTER,	ALL VOLTAGES	RTHB-SU-1080 A
380/450 TON,	LONG SHELLS,	REMOTE STARTER,	ALL VOLTAGES	RTHB-SU-1081 A

DIMENSIONAL DRAWING - EVAPORATOR WATER BOXES

PICK 1 OF THE NEXT 7

1 PASS EVAPORATOR	RTHB-SA-2022 A
2 PASS EVAPORATOR	RTHB-SA-2023 A
3 PASS EVAPORATOR	RTHB-SA-2024 A
4 PASS EVAPORATOR	RTHB-SA-2025 A
2 PASS MARINE WATER BOX - 300 PSI	RTHB-SA-2026 C
3 PASS MARINE WATER BOX - 300 PSI	RTHB-SA-2027 B
4 PASS MARINE WATER BOX - 300 PSI	RTHB-SA-2028 B

DIMENSIONAL DRAWING - CONDENSER WATER BOXES

PICK 1 OF THE NEXT 5

2 PASS CONDENSER 150 PSI	RTHB-SA-2029 A
2 PASS CONDENSER 300 PSI	RTHB-SA-2030 A
3 PASS CONDENSER 150 PSI & 300 PSI	RTHB-SA-2031 A
2 PASS MARINE 300 PSI	RTHB-SA-2032 D
3 PASS MARINE 300 PSI	RTHB-SA-2033 C

RIGGING & WEIGHTS

PICK 1 OF THE NEXT 2

130/450 TON,	STD SHELLS,	ALL STARTERS,	ALL VOLTAGES	5715-0161 C
130/450 TON,	LONG & EXTENDED SHELLS,	ALL STARTERS,	ALL VOLTAGES	5715-0160 B

RTHB PICKLIST - CONTINUED

SCHEMATIC WIRING - PAGE 1 OF 2

PICK 1 OF THE NEXT 4

UNIT MOUNTED STARTER- STAR DELTA (WYE DELTA)	— 2307-5131 B
UNIT MOUNTED STARTER- ACROSS THE LINE (XL)	2307-5132 C
REMOTE MOUNTED STARTER- STAR DELTA (WYE DELTA)	2307-5134 B
REMOTE MOUNTED STARTER- ACROSS THE LINE (XL)	2307-5135 C
UNIT MOUNTED STARTER- SOLID STATE	2307-6503 A

SCHEMATIC WIRING - PAGE 2 OF 2

ALL UNITS	— 2307-5136 D
UNIT MTD - STAR DELTA	
UNIT MTD - ACROSS THE LINE	
UNIT MTD - SOLID STATE	
REMOTE MTD - STAR DELTA	
REMOTE MTD - ACROSS THE LINE	

FIELD WIRING

PICK 1 OF THE NEXT 2

UNIT MOUNTED STARTER	— 2307-5140 D
REMOTE MOUNTED STARTER	2307-6007 B

COMPONENT LOCATION

— 2307-5130 B

DIMENSIONAL DRAWING - OPTION/REMOTE MOUNTED STARTER

PICK 1 OF THE NEXT 8

NO DISCONNECT - TERMINALS ONLY, 155 TO 606 RLA	RTHB-SA-2034 A
NO DISCONNECT - TERMINALS ONLY, 607 TO 1212 RLA	RTHB-SA-2035 A
WITH CIRCUIT BREAKER (C.B.), 155 TO 606 RLA	RTHB-SA-2036 A
WITH CIRCUIT BREAKER (C.B.), 607 TO 960 RLA	RTHB-SA-2037 A
WITH CIRCUIT BREAKER (C.B.), 961 TO 1212 RLA	RTHB-SA-2038 A
MECHANICAL DISCONNECT SWITCH, 155 TO 606 RLA	RTHB-SA-2039 A
MECHANICAL DISCONNECT SWITCH, 607 TO 960 RLA	RTHB-SA-2040 A
MECHANICAL DISCONNECT SWITCH, 961 TO 1212 RLA	RTHB-SA-2041 A

BASE HOLE LOCATION - SUBMIT ON REQUEST ONLY

RTHB-SA-2042 A

SPRING ISOLATORS

RTHB-SA-2043 A

SERVICE LITERATURE

— RTHB-IOM-1

EXHIBIT C

NEW EQUIPMENT SELECTION

Baltimore Aircoil Company
Cooling Tower Selection Program

Version: 7.1.6 NA
 Product data correct as of: July 22, 2009

Project Name: Mt SAC
 Selection Name:
 Project State/Province:
 Project Country: United States
 Date: March 24, 2010

Selection Parameters

Product Line: Series 3000

Design Conditions

Flow Rate: 1200.00 USGPM
 Hot Water Temp.: 95.00 ° F
 Cold Water Temp.: 85.00 ° F
 Wet Bulb Temp.: 69.00 ° F

Selection Requirements

Number of Units: 1 to 9
 Reserve Capability: -5% minimum
 Max. Total Fan Motor Power: 999 HP
 Max. Length (All): 999 feet
 Max. Width: 999 feet
 Max. Height: 999 feet
 Intake Derate Options: None
 Internal Derate Options: None
 Discharge Derate Options: None
 Inches of Water: 0.00
 Fan Type: Standard

User-Chosen Selection

Thermal performance for this selection is certified by the Cooling Tower Institute (CTI).

<u>Qty</u>	<u>Model</u>	Standard Total	Tower	Reserve
		Fan Motor	Pumping	Capability
		<u>HP/Unit</u>	<u>Head (psi)</u>	<u>(%)</u>
1	3272C	15.00	3.74	7.61

This selection assumes an open and unobstructed installation; no external static pressure unless specified above; and, unless specified above no accessories which may affect airflow through the unit, such as capacity control dampers, solid bottom panels, discharge hood, and sound attenuation. If one or more of these assumptions do not apply to this project, please use the program to compute the applicable performance derate or contact your local BAC sales representative.

Centrifugal Chiller

Job Information

Mt Sac Building 2 Chiller Replacement
Los Angeles
(E38)Patrick Bronson



Tag	CTV200T DAY	Model Number	CVHE0320
Quantity	1		

Certified in accordance with the Water-Chilling Packages Using the Vapor Compression Cycle Certification Program, which is based on ARI Standard 550/590.



Sound pressure measured in accordance with ARI Standard 575-94.

ASHRAE 90.1 - 1999	Complies	ASHRAE 90.1 Full Load Requirement: 0.636 kW/ton
ASHRAE 90.1 - 2007	Complies	ASHRAE 90.1 Part Load Requirement: 0.597 kW/ton
ASHRAE 90.1 - 2007 Add. M	Complies	

Unit Information

Model	CVHE	Evap tube type	IMCU
Compressor size	320	Evap tube thickness	0.025"
Motor size	142	Evap passes	2
Motor frequency	60 Hz	Cond shell size	032L
Motor voltage	460	Cond bundle size	250
Impeller size	210	Cond tube type	TECU
Orifice size	250	Cond tube thickness	0.028"
Evap shell size	032S	Cond passes	2
Evap bundle size	280		

Design Information

Cooling capacity	200.0 tons	HCFC-123 refrigerant charge	400 lb
Primary power	109.3 kW	Shipping weight	13035 lb
Primary efficiency	0.546 kW/ton	Operating weight	14187 lb
NPLV	0.516 kW/ton	Sound level	79 dBA
Wye-delta starter type	Unit Mounted WyeD	Green Seal certification	Yes
Application type	Standard cooling	Free cooling option	No
		Heat rejected into equip room	1.87 MBh

Evaporator Information

Evap leaving temp	44.00 F	Evap pressure drop	5.99 ft H2O
Evap flow rate	298.8 gpm	Evap fluid type	water
Evap entering temp	60.00 F	Evap fluid concentration	N/A
Evap flow/capacity	1.49 gpm/ton	Evap water box type	non-marine
Evap fouling factor	0.00010 hr-sq ft-deg F/Btu	Evap water box pressure	150 psig

Condenser Information

Cond entering temp	85.00 F	Cond pressure drop	27.79 ft H2O
Cond flow rate	600.0 gpm	Cond fluid type	water
Cond leaving temp	94.33 F	Cond fluid concentration	N/A
Cond flow/capacity	3.00 gpm/ton	Cond water box type	non-marine
Cond fouling factor	0.00025 hr-sq ft-deg F/Btu	Cond water box pressure	150 psig

Electrical Information

Motor LRA	1257 A	Min circuit ampacity	207 A
Primary RLA	158.1 A	Max overcurrent protection	350 A
Un-corrected power factor	0.89		

Centrifugal Chiller

Job Information

Mt Sac Building 2 Chiller Replacement
Los Angeles
(E38)Patrick Bronson



Tag	CTV200T DAY	Model Number	CVHE0320
Quantity	1		

Information for LEED Projects

HCFC-123 refrigerant charge	400.0 lb	Primary power	109.30 kW
Cooling capacity	200.00 tons	NPLV	0.516 kW/ton

Note: Although Trane recognizes and respects the decision by the U.S. Green Building Council to mandate a default assumption of a 2% Refrigerant Leakage Rate (Lr) for all manufacturers of centrifugal chillers, the value used in the calculations for achieving Energy and Atmosphere Credit 4 of LEED-NC (version 2.2), Trane has exhaustively documented and guarantees a low 0.5% leak rate for HCFC-123 CenTraVac centrifugal chillers (models CVHE, CVHF, and CVHG). This documented 0.5% refrigerant leakage rate, as well as our average 1.7 Lb/Ton refrigerant charge, are just

The LEED Green Building Rating System™, developed by the U.S. Green Building Council, provides independent, third-party verification that a building project meets the highest green building and performance measures

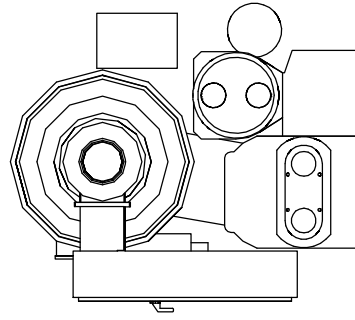
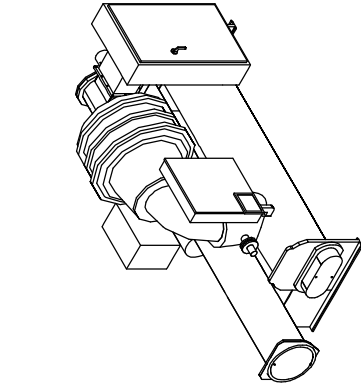

RIGHT SIDE VIEW

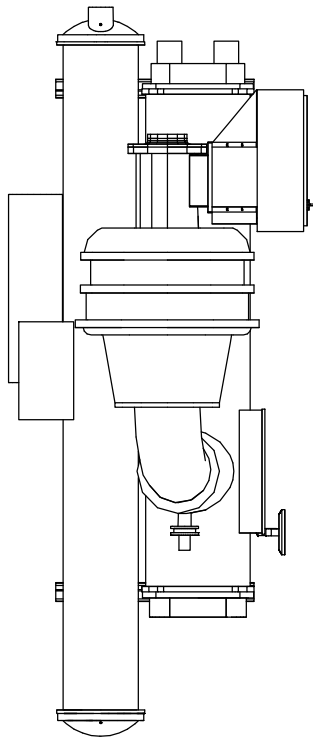

TOP VIEW

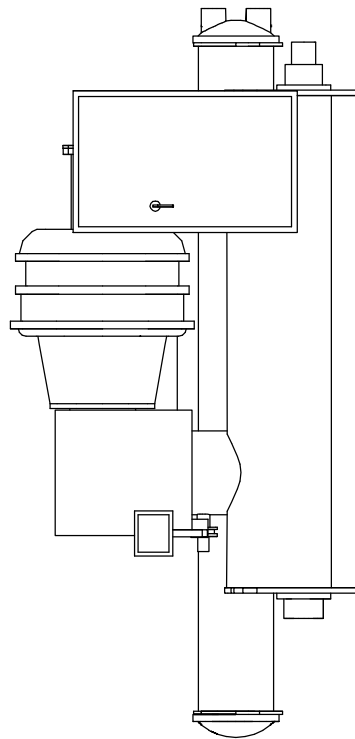

FRONT VIEW

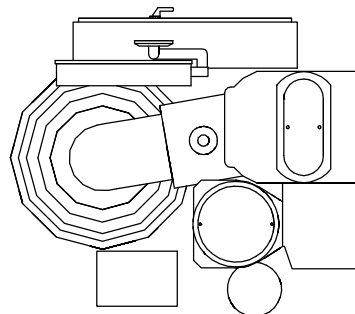
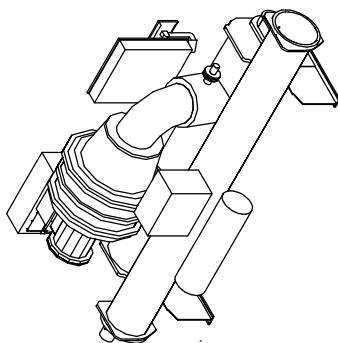

LEFT SIDE VIEW

SHELL TYPE	CONN DIA	CONN TYPE	FLOW DIRECTION
EVAPORATOR COOLING COND	6" 6"	VICTAULIC VICTAULIC	IN REAR OUT FRONT IN BOTTOM OUT TOP

CUSTOMER NOTES:
 UNLESS OTHERWISE SPECIFIED DIMENSIONAL TOLERANCE $\pm 1/2"$.
 COOLING COND CONNS ARE STRAIGHT OUT THE END OF THE WATER BOX.
 WATER BOX DRAIN AND VENT LOCATIONS ARE SHOWN ON THE WATER BOX END PLATES.

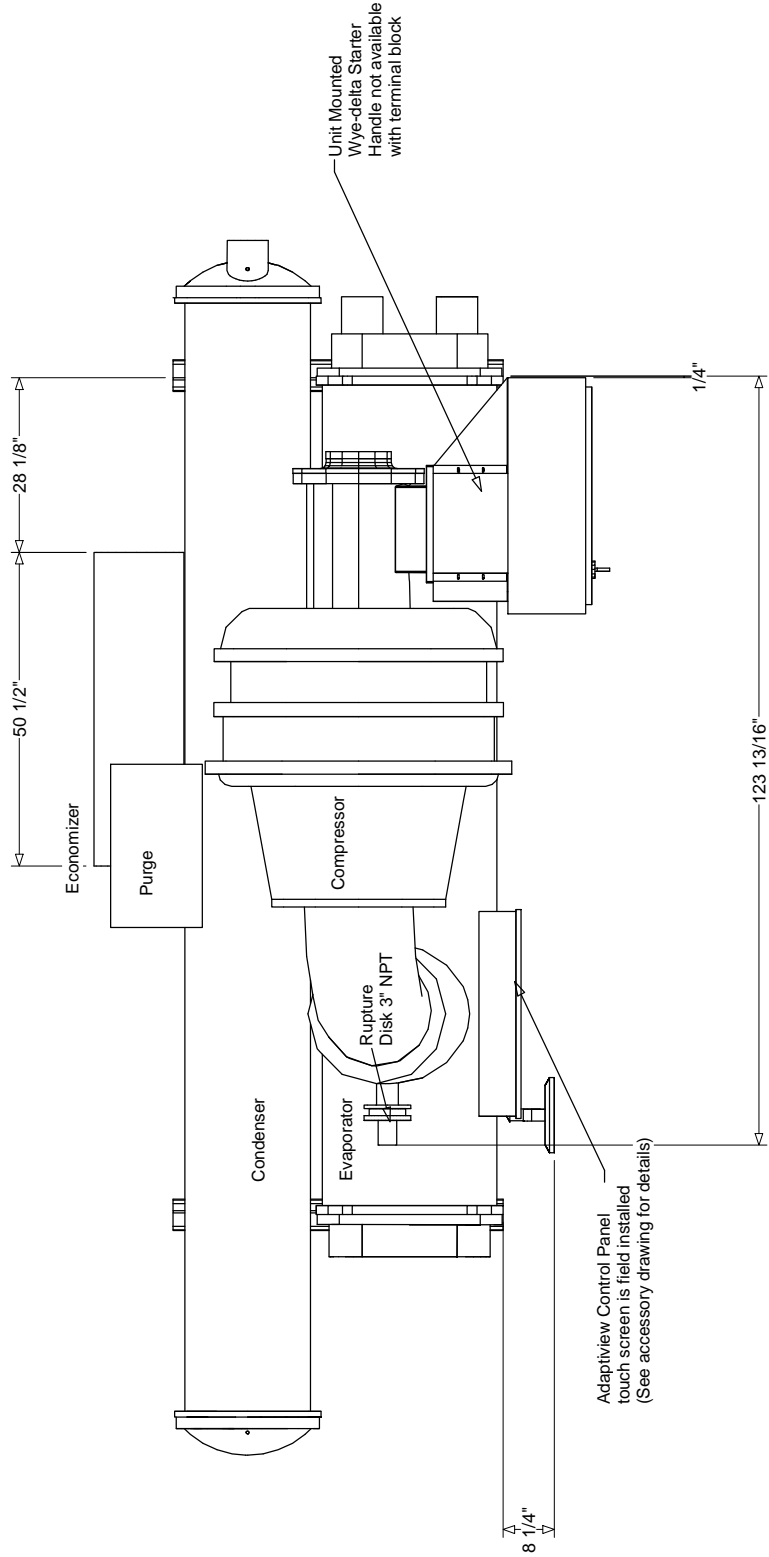

TOP VIEW

SHELL TYPE	CONN DIA	CONN TYPE	FLOW DIRECTION
EVAPORATOR	6"	VICTAULIC	IN REAR OUT FRONT
COOLING COND	6"	VICTAULIC	IN BOTTOM OUT TOP

CUSTOMER NOTES:
 UNLESS OTHERWISE SPECIFIED DIMENSIONAL TOLERANCE +/-1/2".
 COOLING COND CONNS ARE STRAIGHT OUT THE END OF THE WATER BOX.
 WATER BOX DRAIN AND VENT LOCATIONS ARE SHOWN ON THE WATER BOX END PLATES.

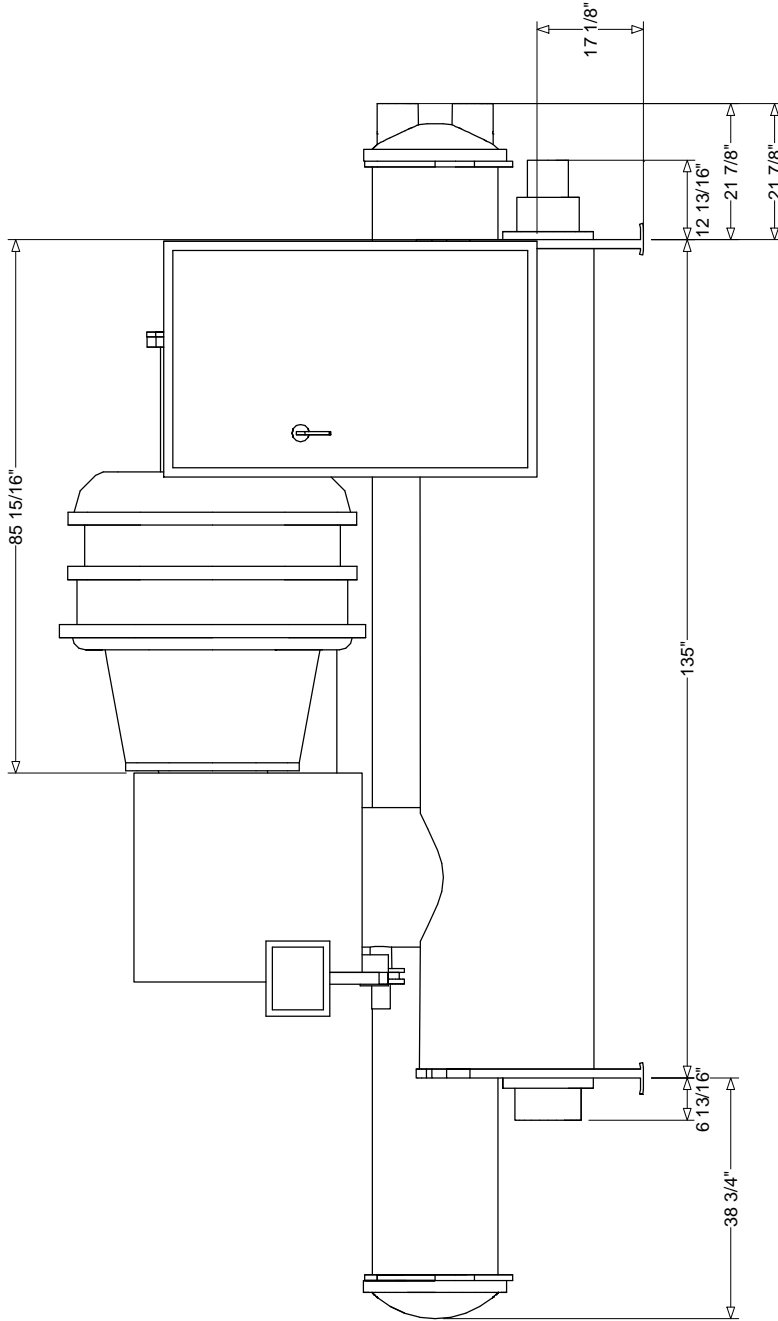

FRONT VIEW

SHELL TYPE	CONN DIA	CONN TYPE	FLOW DIRECTION
EVAPORATOR	6"	VICTAULIC	IN REAR OUT FRONT
COOLING COND	6"	VICTAULIC	IN BOTTOM OUT TOP

CUSTOMER NOTES:
 UNLESS OTHERWISE SPECIFIED DIMENSIONAL TOLERANCE +/- 1/2".
 COOLING COND CONNS ARE STRAIGHT OUT THE END OF THE WATER BOX.
 WATER BOX DRAIN AND VENT LOCATIONS ARE SHOWN ON THE WATER BOX END PLATES.

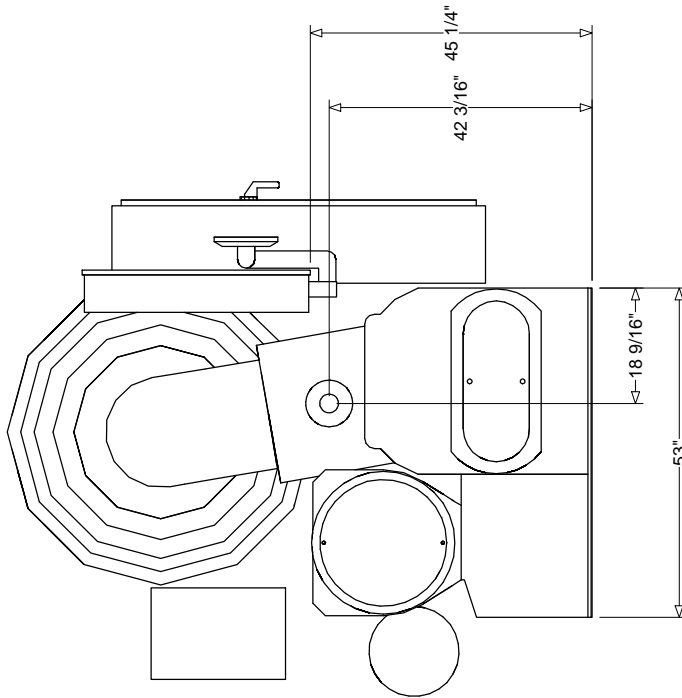

LEFT SIDE VIEW

CUSTOMER NOTES:
 UNLESS OTHERWISE SPECIFIED DIMENSIONAL TOLERANCE +/-1/2".
 COOLING COND CONNS ARE STRAIGHT OUT THE END OF THE WATER BOX.
 WATER BOX DRAIN AND VENT LOCATIONS ARE SHOWN ON THE WATER BOX END PLATES.

SHELL TYPE	CONN DIA	CONN TYPE	FLOW DIRECTION
EVAPORATOR	6"	VICTAULIC	IN REAR OUT FRONT
COOLING COND	6"	VICTAULIC	IN BOTTOM OUT TOP

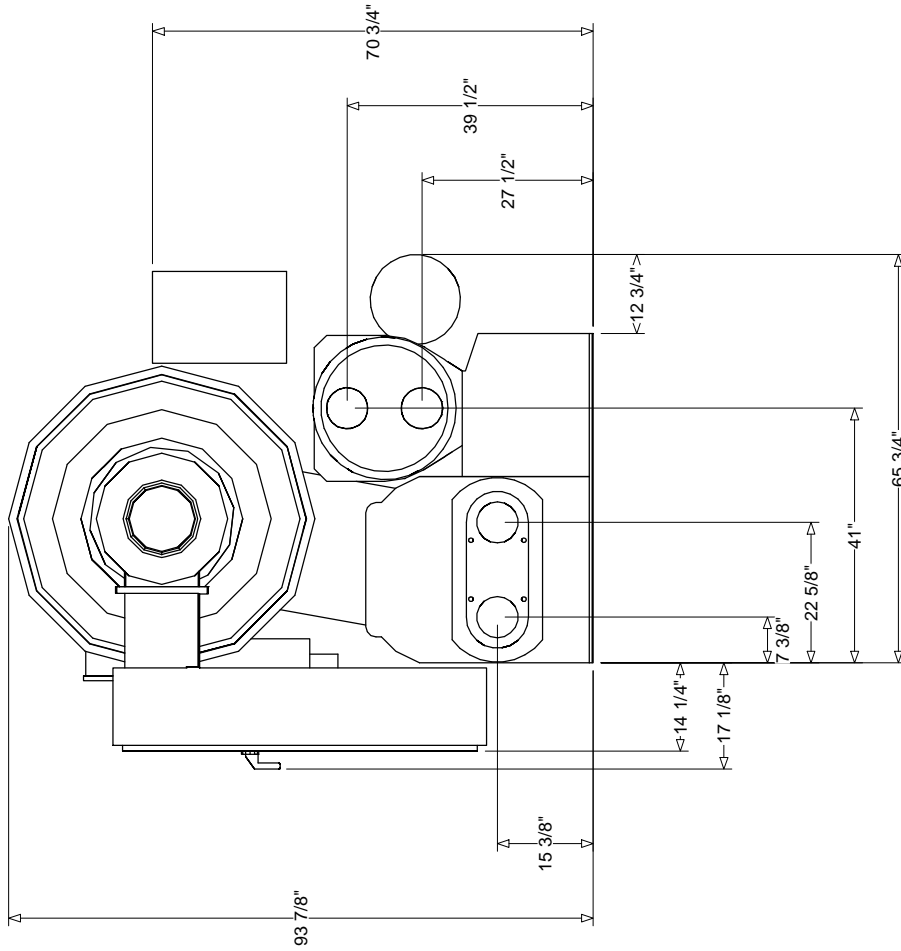

RIGHT SIDE VIEW

SHELL TYPE	CONN DIA	CONN TYPE	FLOW DIRECTION
EVAPORATOR	6"	VICTAULIC	IN REAR OUT FRONT
COOLING COND	6"	VICTAULIC	IN BOTTOM OUT TOP

CUSTOMER NOTES:
 UNLESS OTHERWISE SPECIFIED DIMENSIONAL TOLERANCE +/-1/2".
 COOLING COND CONNS ARE STRAIGHT OUT THE END OF THE WATER BOX.
 WATER BOX DRAIN AND VENT LOCATIONS ARE SHOWN ON THE WATER BOX END PLATES.

CVHE

⚠ WARNING

1. **HEAVY OBJECTS!**
 DO NOT USE CABLES (CHAINS OR SLINGS) EXCEPT AS SHOWN. EACH OF THE CABLES (CHAINS OR SLINGS) USED TO LIFT THE UNIT MUST BE CAPABLE OF SUPPORTING THE ENTIRE WEIGHT OF THE UNIT. LIFTING CABLES (CHAINS OR SLINGS) MAY NOT BE OF THE SAME LENGTH. ADJUST AS NECESSARY FOR EVEN UNIT LIFT. OTHER LIFTING ARRANGEMENTS MAY CAUSE EQUIPMENT OR PROPERTY-ONLY DAMAGE. FAILURE TO PROPERLY LIFT UNIT MAY RESULT IN DEATH OR SERIOUS INJURY. SEE DETAILS BELOW.
2. **IMPROPER UNIT LIFT!**
 TEST LIFT UNIT APPROXIMATELY 24 INCHES TO VERIFY PROPER CENTER OF GRAVITY LIFT POINT. TO AVOID DROPPING OF UNIT, REPOSITION LIFTING POINT IF UNIT IS NOT LEVEL. FAILURE TO PROPERLY LIFT UNIT COULD RESULT IN DEATH OR SERIOUS INJURY OR POSSIBLE EQUIPMENT OR PROPERTY-ONLY DAMAGE.
3. ATTACH SAFETY CHAIN OR CABLE AS SHOWN WITHOUT TENSION, NOT AS A LIFTING CHAIN OR CABLE, BUT TO PREVENT THE UNIT FROM ROLLING.
4. DO NOT FORKLIFT THE UNIT TO MOVE OR LIFT.
5. LIFTING HOLES PROVIDED ON CHILLER TO ATTACH CABLES (CHAINS OR SLINGS).
6. 36" (900 MM) RECOMMENDED CLEARANCE ABOVE HIGHEST POINT OF COMPRESSOR.
7. FOLLOW NEC SECTION 110 AND OTHER APPLICABLE LOCAL CODES FOR CLEARANCES IN FRONT OF ELECTRICAL ENCLOSURES.
8. SPECIFIC SHIPPING AND OPERATING WEIGHTS OF THE SUBMITTED CHILLER ARE PROVIDED IF THE CENTRIFUGAL CHILLER SELECTION WAS ENTERED IN TOPSS. DETAILED LOAD POINT AND SPRING ISOLATOR APPLICATION WEIGHTS ARE AVAILABLE FROM "CENTRAVAC ISOLATOR SELECTION REPORT" AVAILABLE FROM THE REPORT GENERATOR OF THE TRANE TOPSS CHILLER SELECTION PROGRAM. CONTACT YOUR LOCAL TRANE SALES ENGINEER IF THIS DATA IS REQUIRED.

(SEE NOTE 8 ABOVE)	
MAXIMUM SHIPPING	13035.0 lb
MAXIMUM OPERATING	14187.0 lb

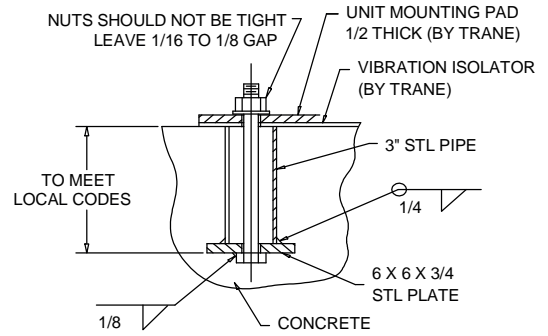

ANCHOR BOLT DETAIL
 RECOMMENDED PROCEDURE TO ALLOW FOR THERMAL EXPANSION (UNLESS OTHERWISE SPECIFIED, PARTS ARE FURNISHED BY CUSTOMER). ANCHORING THE UNIT IS NOT A REQUIREMENT, IT MAY BE RECOMMENDED FOR SPECIFIC APPLICATIONS.

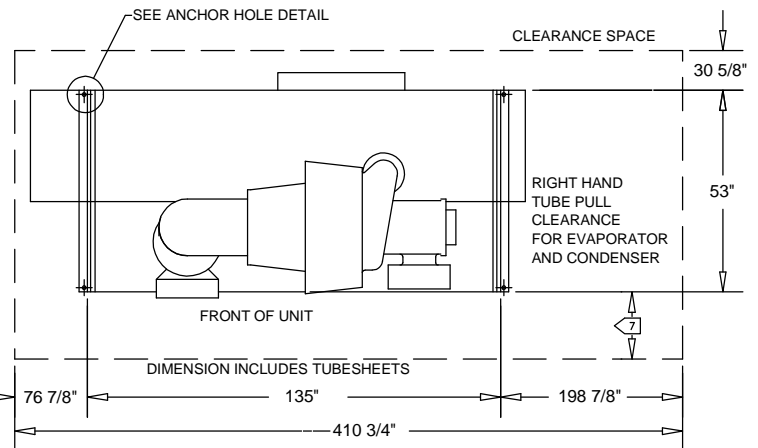
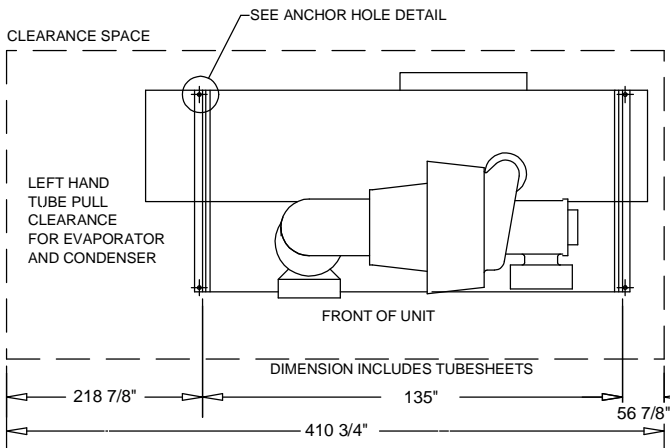
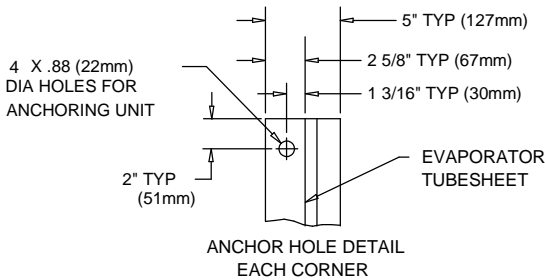
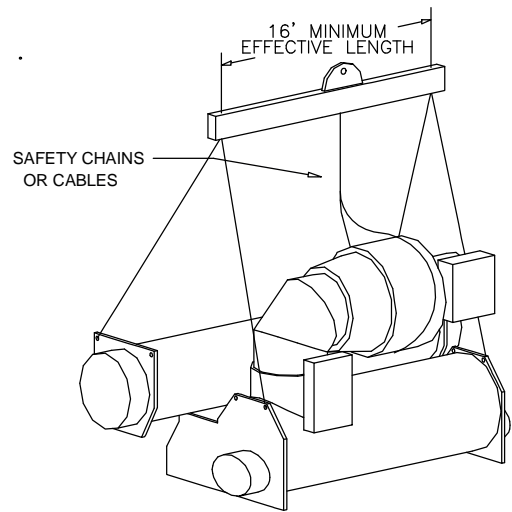
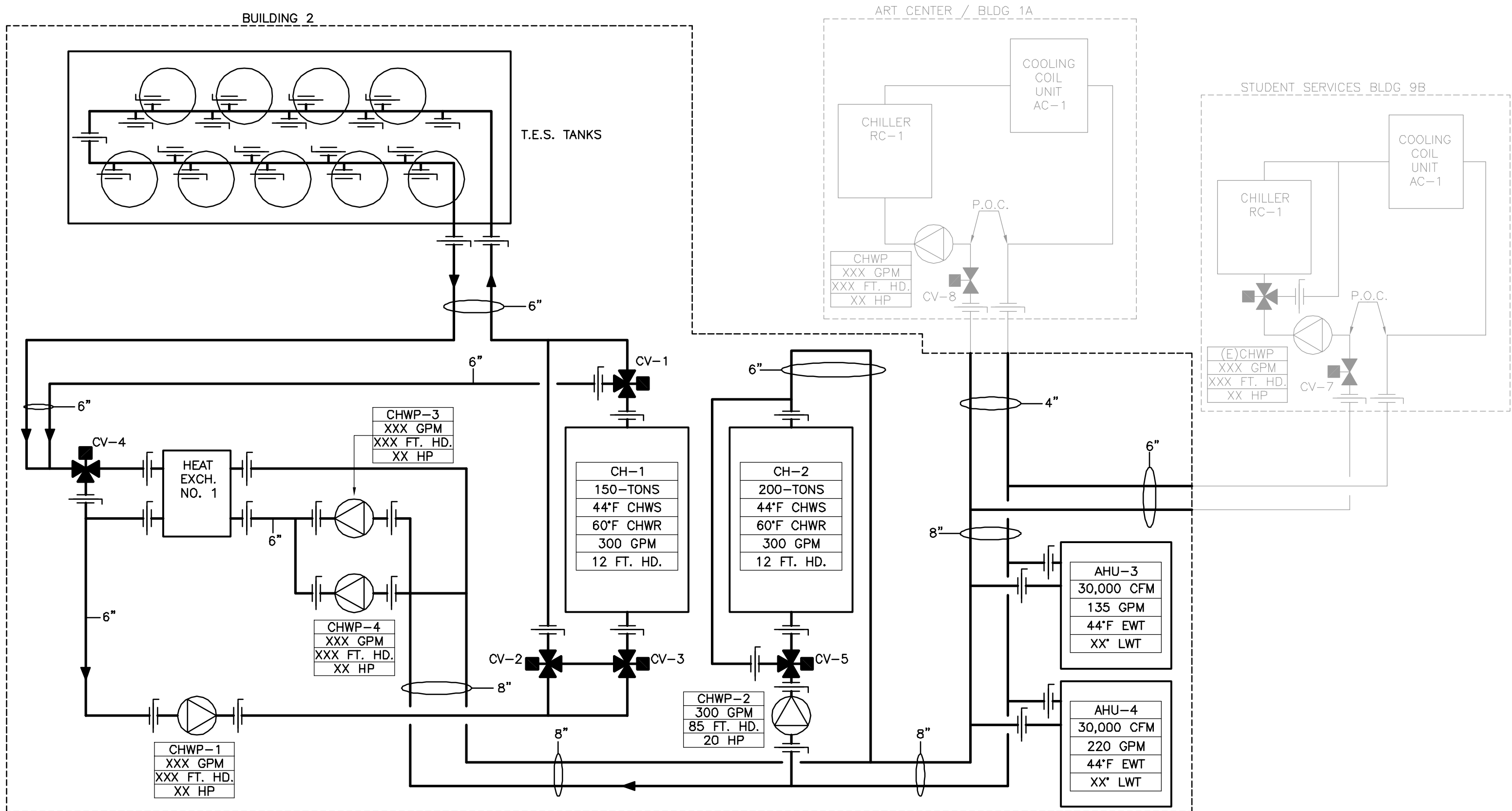
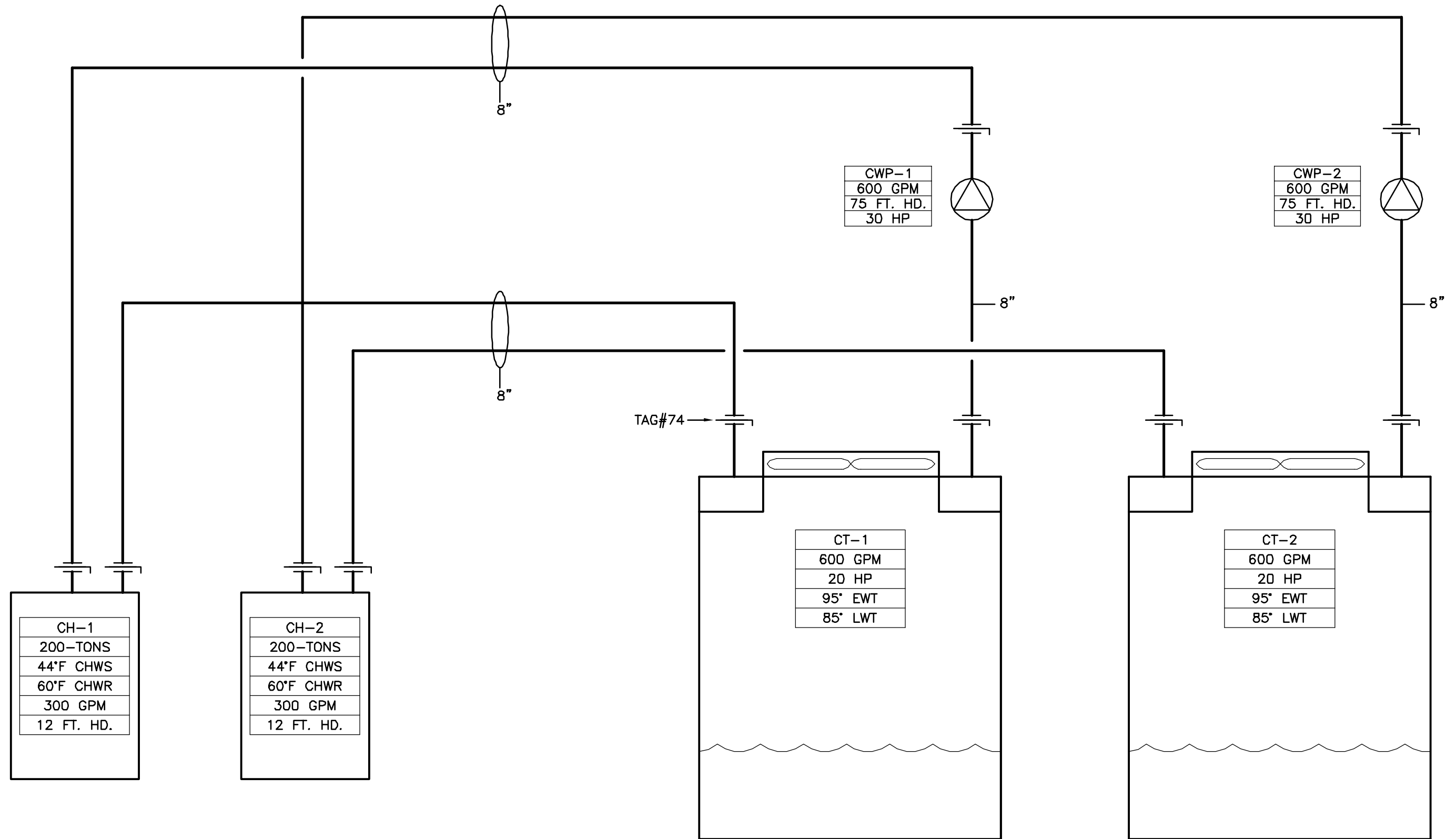

EXHIBIT D

BUILDING 2 PLANT SCHEMATICS



GLYCOL & CHILLED WATER VALVE CHART / FLOW SCHEMATIC



CONDENSER WATER SYSTEM VALVE CHART / FLOW SCHEDULE

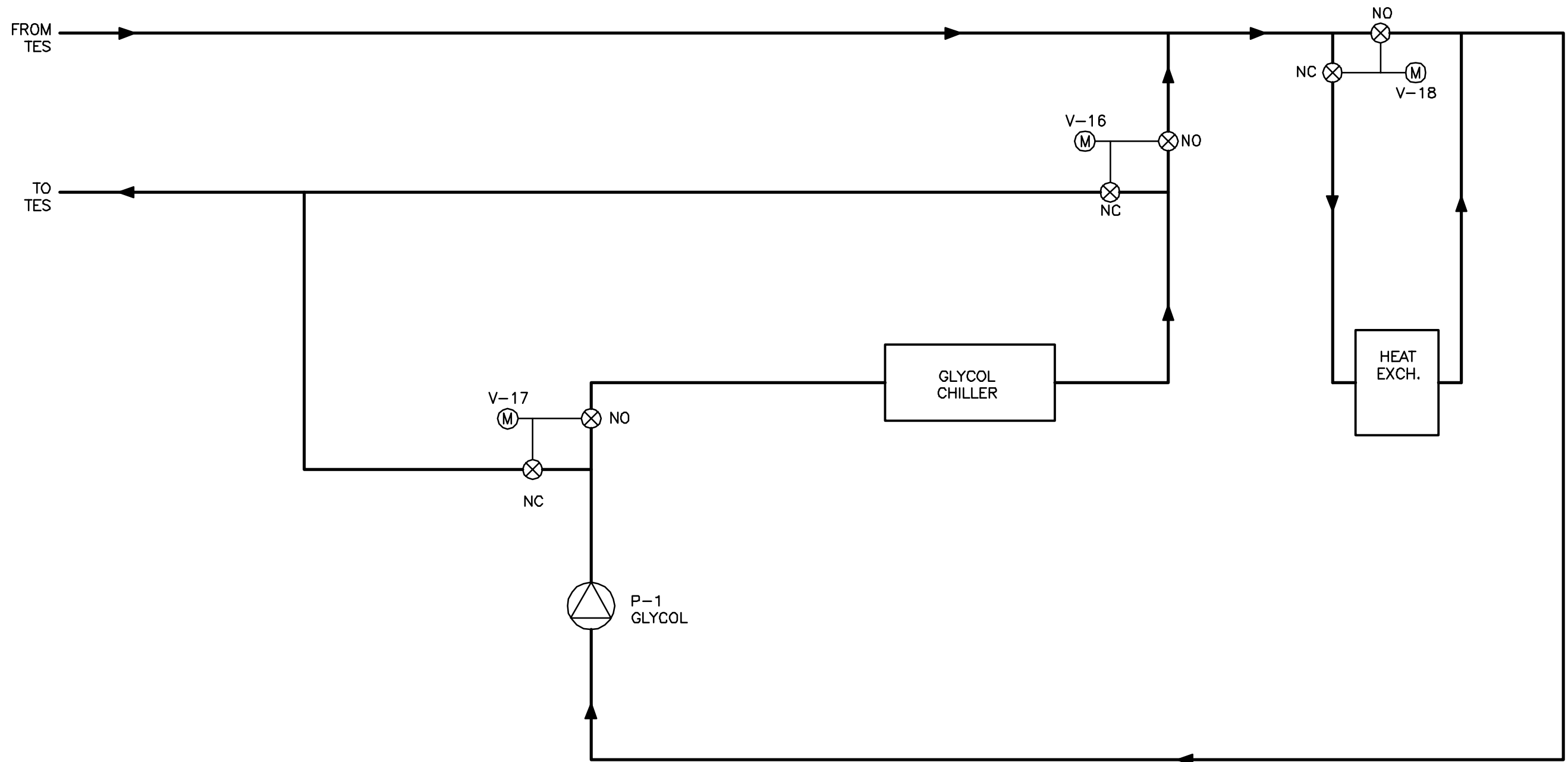

GLYCOL LOOP SCHEMATIC
 CHARGE MODE; CHILLER TEMP SET TO 26°F

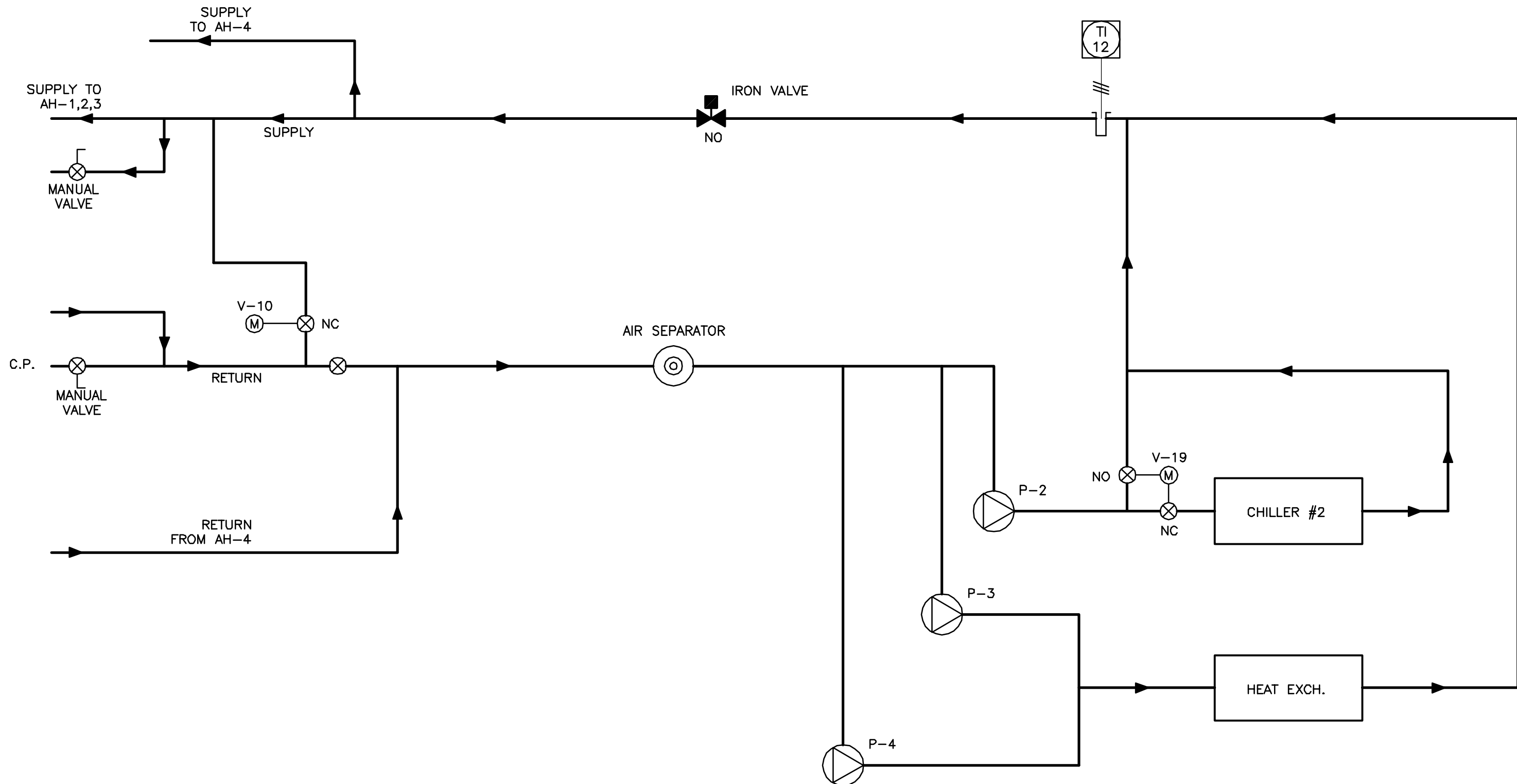

CURRENT CONDITION OF P-4;
 ALWAYS ON. CANNOT RUN P-3 AND
 P-4 AT THE SAME TIME; YOU WILL
 STARVE CHILLER #2

CHILLED WATER LOOP
 WHEN CHILLER #2 IS ONLINE
 IF TEMP REACHES 46°F LEAVING, CHILLER 2 STARTS

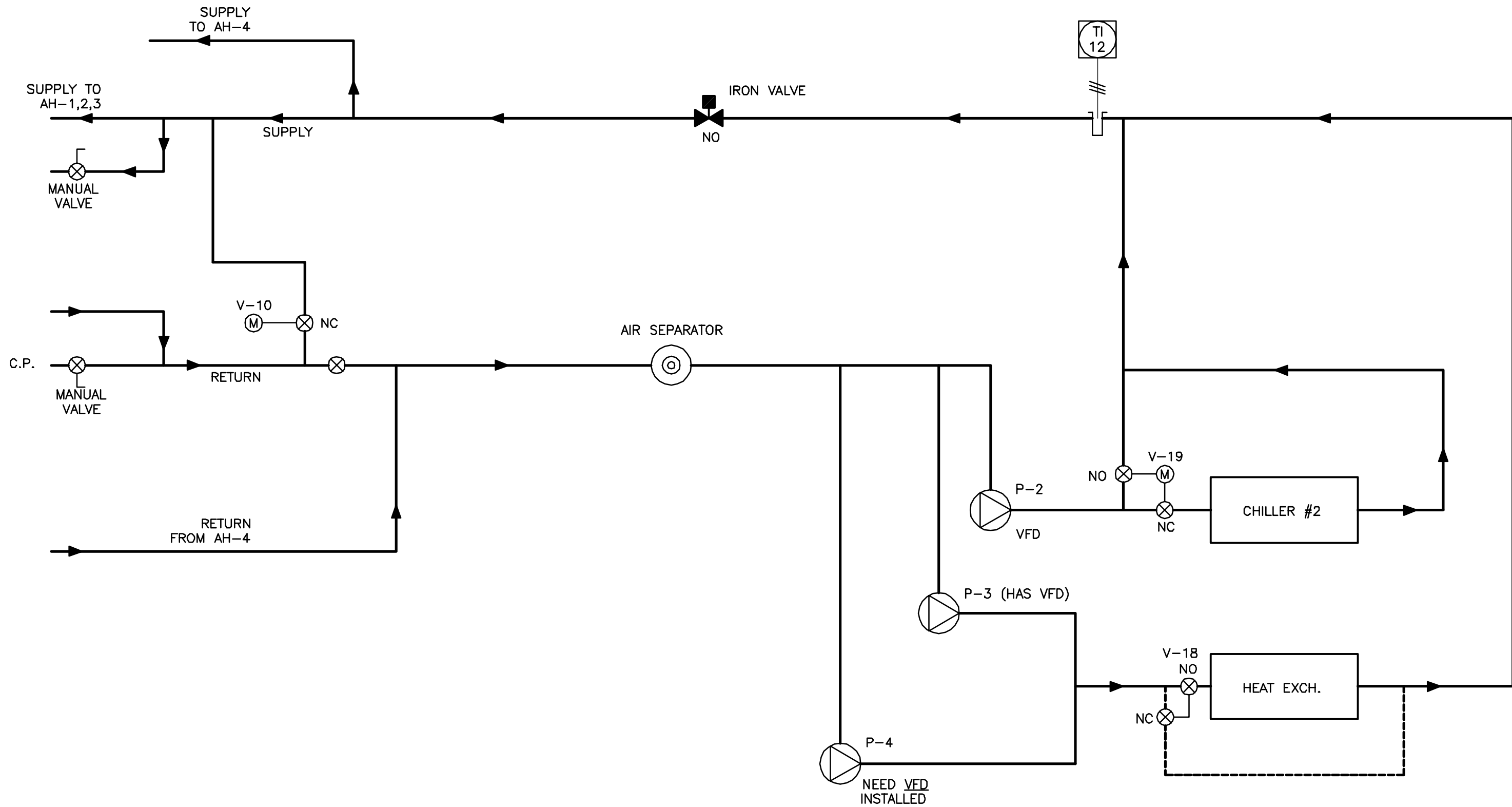

CHILLED WATER LOOP
 DISCHARGE MODE; USE UNTIL CHILLED WATER RUNS OUT.
 USING UP THE ICE IN TES TANKS

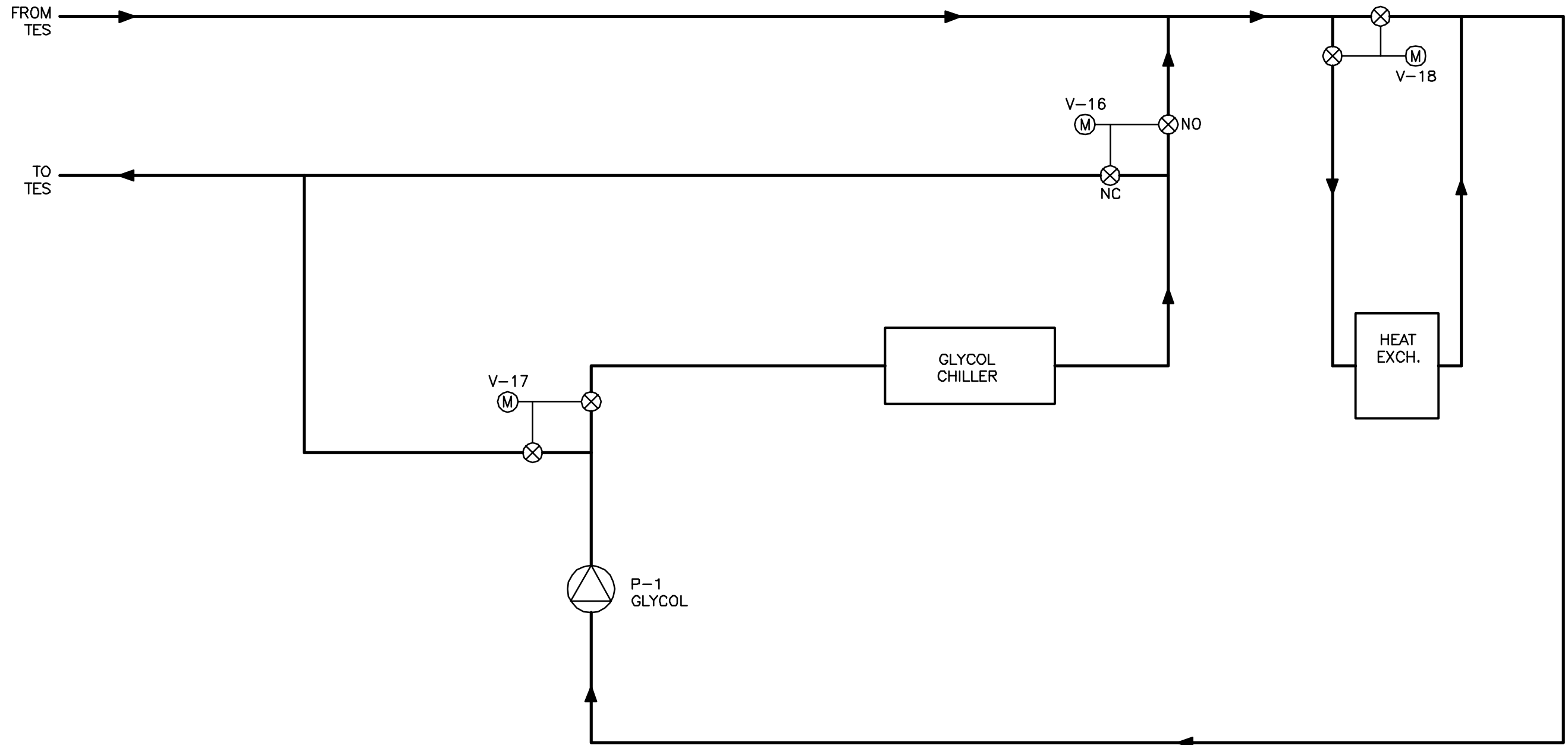

GLYCOL LOOP SCHEMATIC
 IN CASE CHILLER 2 FAILS, RUN CHILLER #1 IN THIS MODE

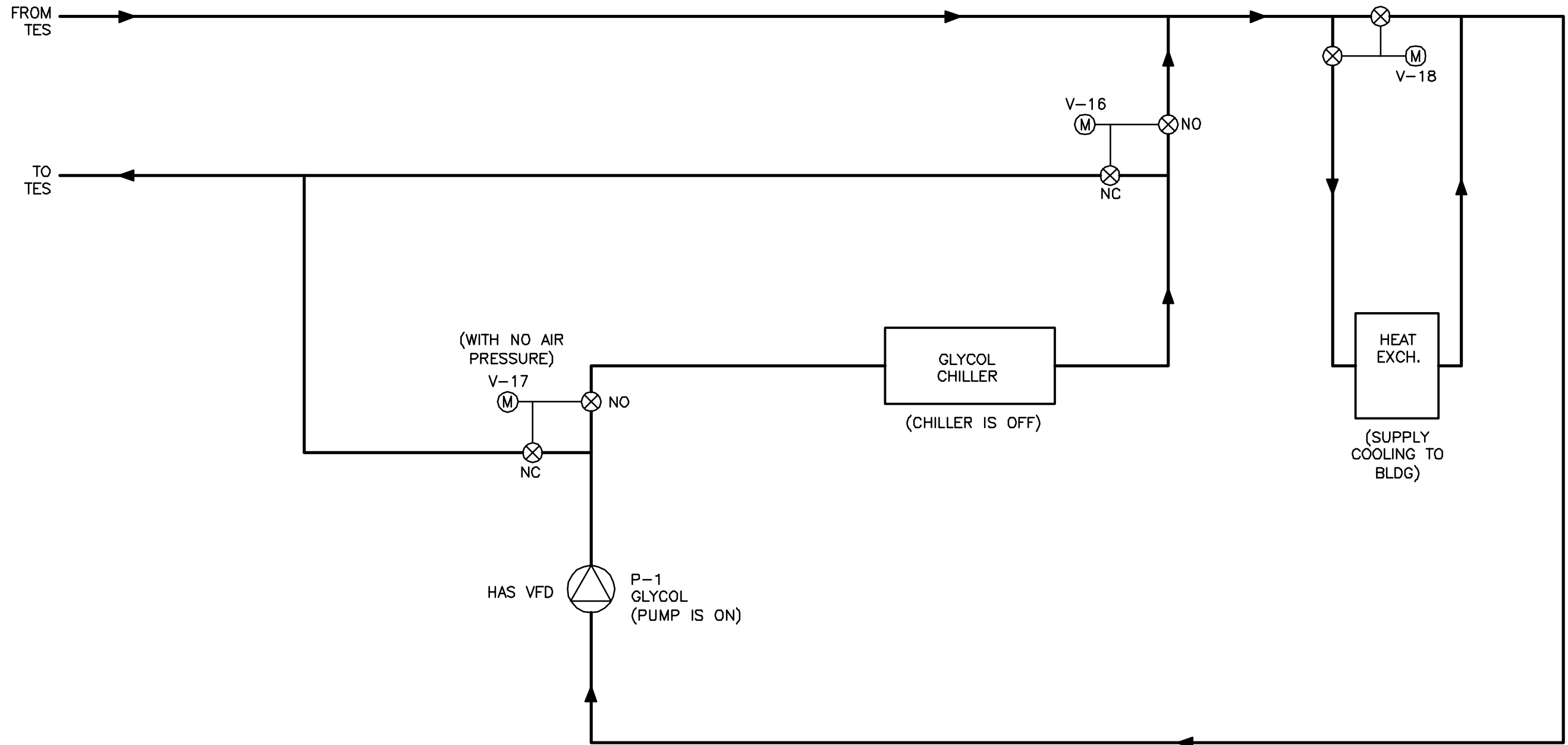

GLYCOL LOOP SCHEMATIC
HARVEST MODE OR DISCHARGE

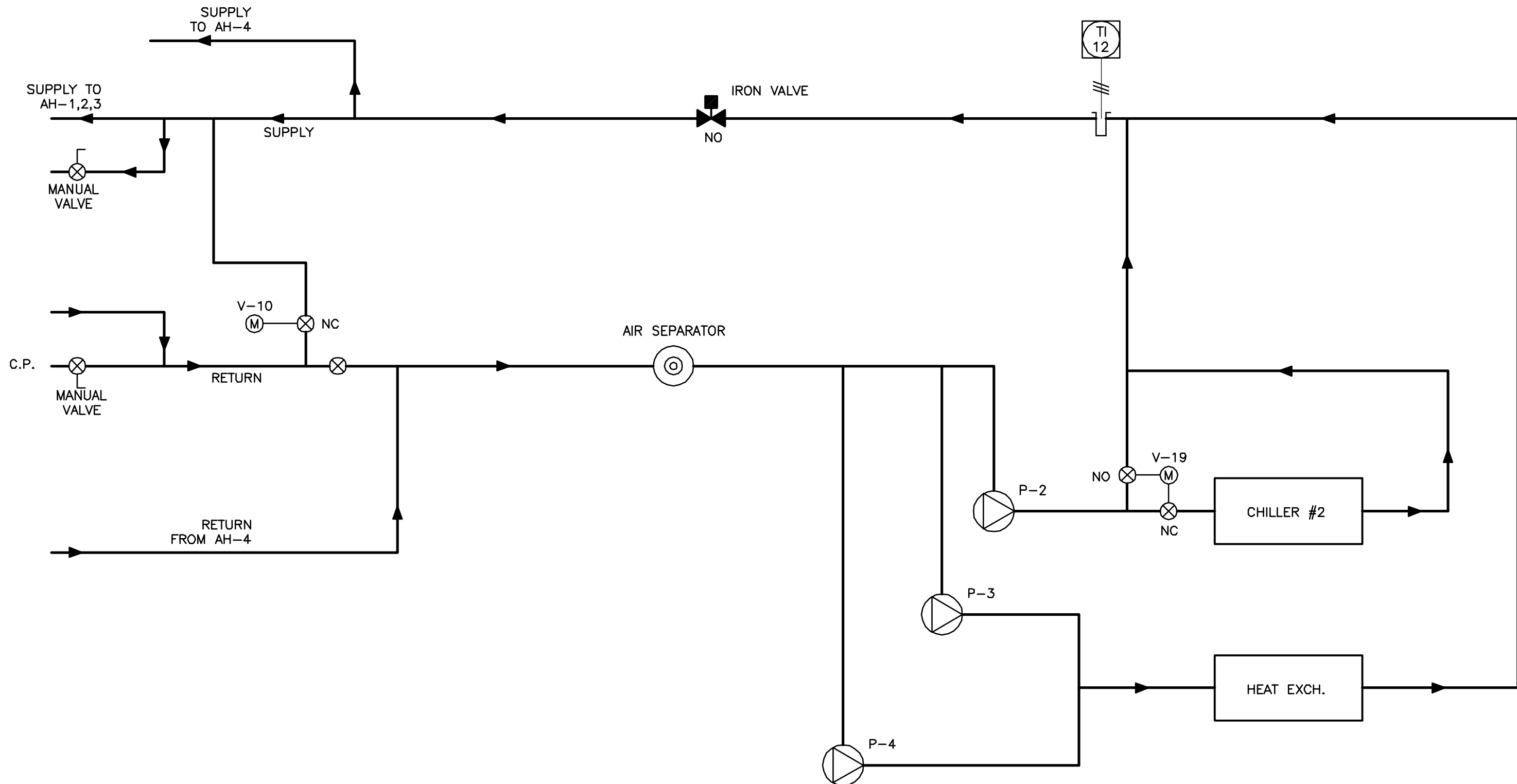

CURRENT CONDITION OF P-4;
 ALWAYS ON. CANNOT RUN P-3 AND
 P-4 AT THE SAME TIME; YOU WILL
 STARVE CHILLER #2

CHILLED WATER LOOP
 WHEN CHILLER #2 IS ONLINE
 DISCHARGE MODE

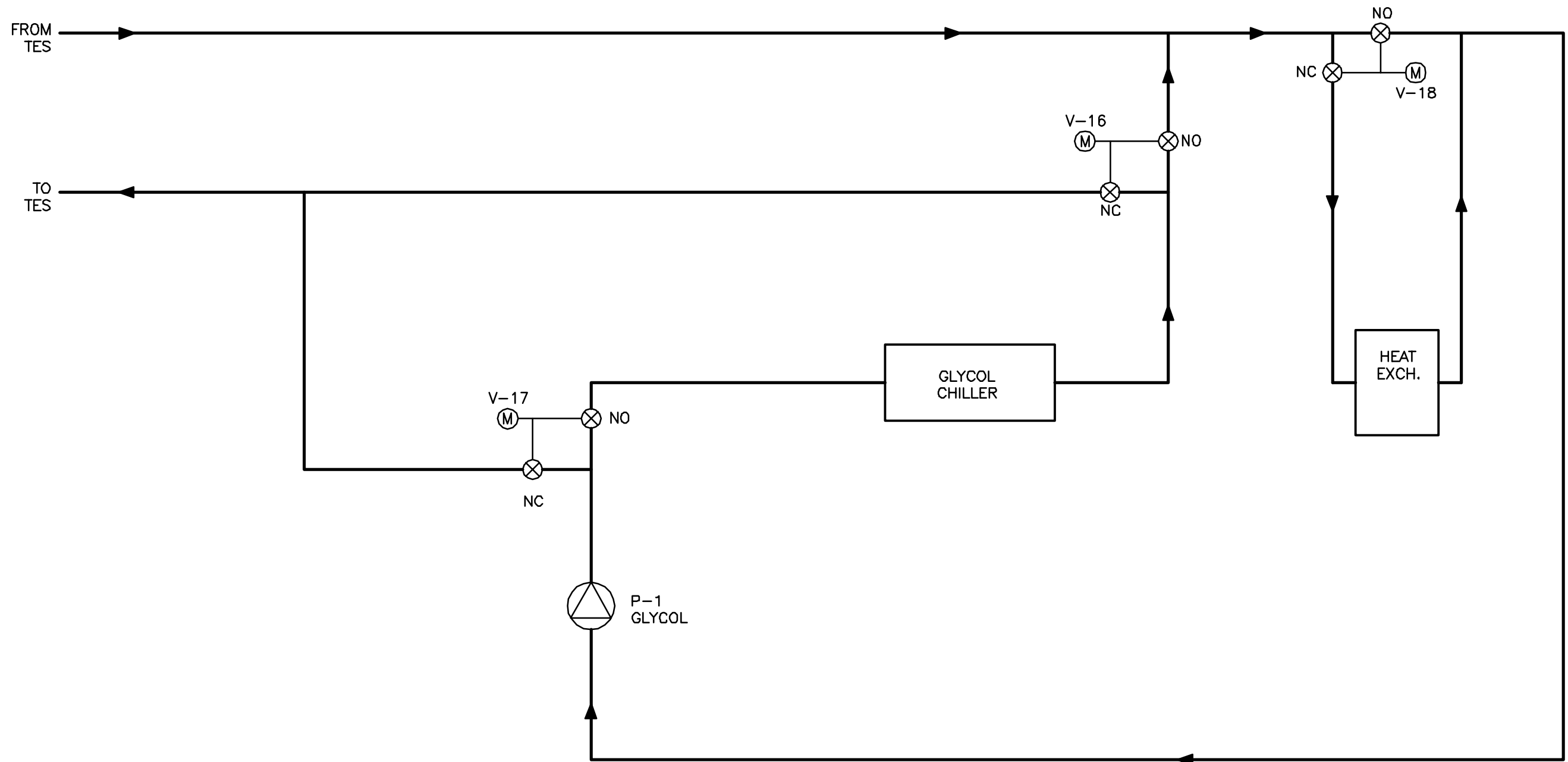

GLYCOL LOOP SCHEMATIC
DISCHARGE MODE